



ACVATIX™

Modulating refrigerant valves with magnetic actuator, PS45

MVL661...-..

Hermetically sealed, for safety refrigerants

- One valve type for expansion, hot-gas and suction throttle applications
- Hermetically sealed towards outside
- Selectable standard interface DC 0/2...10 V or DC 0/4...20 mA
- High resolution and control accuracy
- Precise positioning control and position feedback signal
- Short positioning time (< 1 s)
- Closed when deenergized
- Robust and maintenance-free
- Five valve sizes with k_{vs} values from 0.25 to 12 m³/h

Use

The MVL661...-.. refrigerant valve is designed for modulating control of refrigerant circuits including chillers and heat pumps. It can be used in expansion, hot-gas and suction throttle applications as well as with all commonly used safety refrigerants (R22, R134a, R404A, R407C, R410A, R507, etc.) and R744 (CO₂). Not suitable for inflammable refrigerants.

Type summary

Type reference	DN	k_{vs} [m ³ /h]	k_{vs} reduced ¹⁾ [m ³ /h]	Δp_{max} [MPa]	$Q_0 E$ [kW]	$Q_0 H$ [kW]	$Q_0 D$ [kW]
MVL661.15-0.4	15	0.40		2.5	47	9.2	1.7
			0.25		29	5.7	1.0
MVL661.15-1.0	15	1.0			117	23	4.2
			0.63		74	14	2.6
MVL661.20-2.5	20	2.5			293	57	10
			1.6		187	37	6.6
MVL661.25-6.3	25	6.3			737	144	26
			4		468	92	17
MVL661.32-12	32	12		2)	2)	50	
			8	0.2	2)	2)	33

¹⁾ 63% of k_{vs} , refer to "k_{vs} reduction" on page 4

²⁾ MVL661.32-12.0 is only approved for suction throttle applications

k_{vs} Nominal flow rate of refrigerant through the fully open valve (H_{100}) at a differential pressure of 100 kPa (1 bar) to VDI 2173

$Q_0 E$ Refrigeration capacity in expansion applications

$Q_0 H$ Refrigeration capacity in hot-gas bypass applications

$Q_0 D$ Refrigeration capacity in suction throttle applications and $\Delta p = 0.5$ bar

Q_0 With R407C at $t_0 = 0$ °C, $t_c = 40$ °C

The pressure drop across evaporator and condenser is assumed to be 0.3 bar each, and 1.6 bar upstream of the evaporator (e.g. spider).

The capacities specified are based on superheating by 6 K and subcooling by 2 K.

The refrigeration capacity for various refrigerants and operating conditions can be calculated for the 3 types of application using the tables at the end of this data sheet. For accurate valve sizing, we recommend the valve selection program "Refrigeration VASP".

Ordering

Valve body and magnetic actuator form one integral unit and cannot be separated.

Example:

Product number	Stock number	Designation	Quantity
MVL661.15-0.4	MVL661.15-0.4	Refrigerant valve	1

Spare parts

If the valve's electronics become faulty, the entire electronics housing must be replaced by spare part ASR61, supplied complete with mounting instructions (74 319 0270 0).

Rev. no.

See table on page 17.

Function / mechanical design

Features and benefits

- 4 selectable standard signals for setpoint and measured value
- DIP switch to reduce the k_{vs} value to 63% of the nominal value
- Potentiometer for adjustment of minimum stroke for suction throttle applications
- Automatic stroke calibration
- Forced control input for "Valve closed" or "Valve fully open"
- LED for indicating the operating state

The MVL661... can be driven by Siemens or third-party controllers that deliver a DC 0/2...10 V or DC 0/4...20 mA output signal.

For optimum control performance, we recommend a 4-wire connection between controller and valve. When operating on DC voltage, a 4-wire connection is **mandatory!** The valve stroke is proportional to the control signal.

Operator controls and indicators in the electronics housing

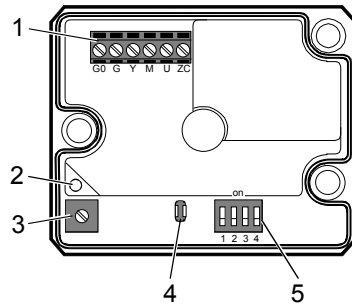

- 1 Connection terminals
- 2 LED for indication of operating state
- 3 Minimal stroke setting potentiometer Rv
- 4 Autocalibration
- 5 DIL switches for mode control

Configuration of DIL switches

Switch	Function	ON / OFF	Description
 1	Positioning signal Y	ON	Current [mA]
		OFF	Voltage [V] ¹⁾
 2	Positioning range Y and U	ON	DC 2...10 V, 4...20 mA
		OFF	DC 0...10 V , 0...20 mA ¹⁾
 3	Position feedback U	ON	Current [mA]
		OFF	Voltage [V] ¹⁾
 4	Nominal flow rate k_{vs}	ON	63%
		OFF	100% ¹⁾

¹⁾ **Factory setting**

k_{vs} -reduction

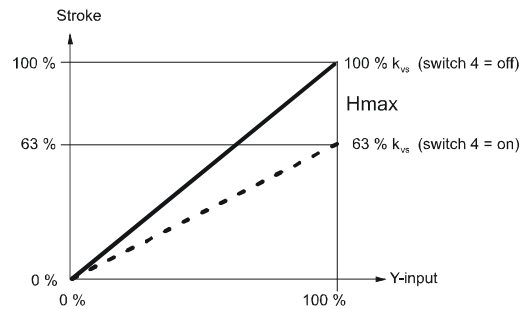

For k_{vs} reduction (DIL switch 4 in position ON), the stroke is limited to 63% mechanical stroke. 63% of full stroke then corresponds to an input/output signal of 10 V. If, in addition, the stroke is limited to 80%, for example, the minimum stroke is $0.63 \times 0.8 = 0.50$ of full stroke.

Minimum stroke setting

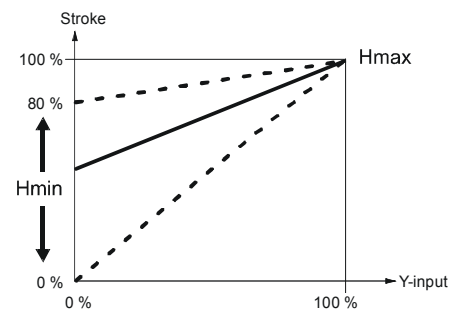

In the case of a suction throttle valve, it is essential that a minimum stroke limit be maintained to ensure compressor cooling and efficient oil return. This can be achieved with a reinjection valve, a bypass line across the valve, or a guaranteed minimum opening of the valve. The minimum stroke can be defined via the controller and control signal Y, or it can be set directly with potentiometer Rv.

The **factory setting** is zero (mechanical stop in counterclockwise direction, CCW). The minimum stroke can be set by turning the potentiometer clockwise (CW) to a maximum of 80% k_{vs} .

Caution

Do not under any circumstances use potentiometer Rv to limit the stroke on expansion applications. It must be possible to close the valve fully.

Forced control input ZC

		ZC – Function		
		No function	Fully open	Closed
Connections				
	Transfer			
function		<ul style="list-style-type: none"> ZC not connected Valve will follow the Y-signal Minimum stroke setting with potentiometer Rv possible 	<ul style="list-style-type: none"> ZC connected to G Valve will fully open control path A → AB 	<ul style="list-style-type: none"> ZC connected to G0 Valve will close control path A → AB

Signal priority

1. Forced control signal ZC
2. Signal input Y and/or minimum stroke setting with potentiometer Rv possible.

Calibration

The printed circuit board of the MVL661... has a slot to facilitate calibration. To calibrate, insert a screwdriver in the slot so that the contacts inside are connected. As a result, the valve will first be fully closed and then fully opened.

Calibration matches the electronics to the valve mechanism.

During calibration, the green LED flashes for about 10 seconds; refer to "Indication of operating state" (page 4).

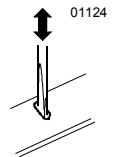

MVL661... refrigerant valves are supplied fully calibrated.

When is a calibration required?

Execute a calibration after replacing the electronics, when the red LED is lit or flashing or when the valve is leaking (at seat).

Indication of operating state

LED	Indication	Function	Remarks, troubleshooting
Green	Lit	Control mode	Automatic operation; everything o.k.
	Flashing	Calibration in progress	Wait until calibration is finished (green or red LED will be lit)
Red	Lit	Calibration error Internal error	Recalibrate (operate button in opening 1x) Replace electronics module
	Flashing	Mains fault	Check mains network (outside the frequency or voltage range)
Both	Dark	No power supply Electronics faulty	Check mains network, check wiring Replace electronics module

Connection type ¹⁾

Always give preference to a 4-wire connection!

4-wire connection
3-wire connection

Product number	S _{NA} [VA]	P _{MED} [W]	I _F [A]	Wire cross-section [mm ²]		
				1.5	2.5	4.0 ²⁾
				max. cable length L [m]		
MVL661...-	22	12	1.6...4 A	65	110	160
MVL661...-	22	12	1.6...4 A	20	35	50

S_{NA} = Nominal apparent power for selecting the transformer

P_{med} = Typical power consumption

I_F = Required slow fuse

L = Max. cable length; with 4-wire connections, the max. permissible length of the separate 1.5 mm² copper positioning signal wire is 200 m

¹⁾ All information at AC 24 V

²⁾ With 4 mm² electrical wiring reduce wiring cross-section for connection inside valve to 2.5 mm².

Sizing

For straightforward valve sizing, refer to the tables for the relevant application (from page 13).

For accurate valve sizing, we recommend to make use of the valve sizing software "Refrigeration VASP", available from your local Siemens office.

Notes

The refrigeration capacity Q₀ is calculated by multiplying the mass flow by the specific enthalpy differential found in the h, log p-chart for the relevant refrigerant. To help determine the refrigeration capacity more easily, a selection chart is provided for each application (page 9 and following). With direct or indirect hot-gas bypass applications, the enthalpy differential of Q_c (the condenser capacity) must also be taken into account when calculating the refrigeration capacity.

If the evaporating and / or condensing temperatures are between the values shown in the tables, the refrigeration capacity can be determined with reasonable accuracy by linear interpolation (refer to the application examples on page 9 and following).

At the operating conditions given in the tables, the permissible differential pressure Δp_{max} (25 bar) across the valve is within the admissible range for these valves.

If the evaporating temperature is raised by 1 K, the refrigeration capacity increases by about 3%. If, by contrast, subcooling is increased by 1 K, the refrigeration capacity increases by about 1 to 2% (this applies only to subcooling down to approximately 8 K).

Engineering notes

Depending on the application, additional installation instructions may need to be observed and appropriate safety devices (e.g. pressostats, full motor protection, etc.) fitted.

Warning

To prevent damage to the seal inside the valve insert, the plant must be vented on the low-pressure side following a pressure test (valve port AB), or the valve must be fully open during the pressure test and during venting (power supply connected and positioning signal at maximum or forced opening by G → ZC).

Expansion application

To prevent formation of flash gas on expansion applications, the velocity of the refrigerant in the fluid pipe may not exceed 1 m/s. To assure this, the diameter of the fluid pipe must be greater than the nominal size of the valve, using reducing pieces for making the connections to the valve.

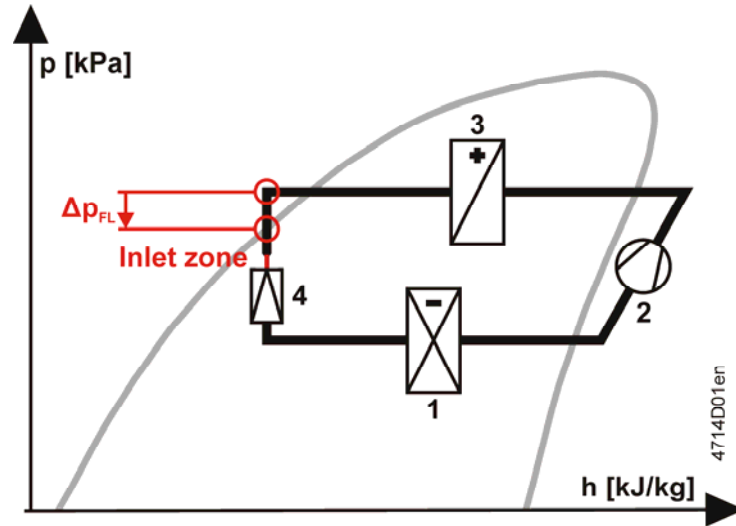

- 1 = Evaporator
- 2 = Compressor
- 3 = Condenser
- 4 = Expansion valves

- a) The differential pressure over reduction must be less than half the differential pressure Δp_{FL} .
- b) The inlet path between diameter reduction and expansion valve inlet
 - Must straight for at least 600 mm
 - May not contain any valves

**A filter / dryer must be mounted upstream of the expansion valve.
The valve is not explosion-proof.
It is not approved for use with ammonia (NH3, R717).**

Mounting notes

The valve should be mounted and commissioned by qualified staff. The same applies to the replacement electronics and the configuration of the controller (e.g. SAPHIR or PolyCool).

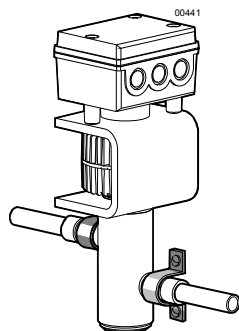
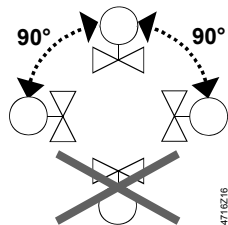

- The refrigerant valves can be mounted in any orientation, but upright mounting is preferable.
- Arrange the pipework in such a way that the valve is not located at a low point in the plant where oil can collect.
- The pipes should be fitted in such a way that the alignment does not distort the valve connections. Fix the valve body so that that it cannot vibrate. Vibration can lead to burst connection pipes.
- Before soldering the pipes, ensure that the direction of flow through the valve is correct.
- The pipes must be soldered with care. To avoid dirt and the formation of scale (oxide), inert gas is recommended for soldering.
- The flame should be large enough to ensure that the junction heats up quickly and the valve does not get too hot.
- The flame should be directed away from the valve.
- During soldering, cool the valve with a wet cloth, for example, to ensure that it does not become too hot.
- Port B must be sealed off when a 2-port valve (AB → A) is used.
- The valve body and the connected pipework should be lagged.
- The actuator must not be lagged.

The valve is supplied complete with mounting instructions 74 319 0232 0.

Maintenance

The refrigerant valve is maintenance-free.

Repair

The valve can not be repaired. It has to be replaced as a complete unit.

Disposal



Do not dispose of the actuator and its electrical and electronic components with domestic waste.

The law may require special handling of certain components or it may make sense from an ecological point of view.

Observe all applicable local laws.

Warranty

Observe all application-specific technical data.

If you ignore specified limits, Siemens Building Technologies / CPS Products will nor assume any responsibility.

Technical data

Functional actuator data

Power supply	Extra low-voltage only (SELV, PELV)			
• AC 24 V	Operating voltage	AC 24 V \pm 20%		
	Frequency	45...65 Hz		
	Typical power consumption P_{med}		12 W	
		Standby	< 1 W (valve closed)	
	Rated apparent power S_{NA}	22 VA (for selecting the transformer)		
	Required fuse	1.6...4 A (slow)		
• DC 24 V	Operating voltage	DC 20...30 V		
	Current draw	0.5 A / 2 A (max.)		
Signal inputs	Control signal Y	DC 0/2...10 V or DC 0/4...20 mA		
	Impedance DC 0/2...10 V	100 k Ω / 5nF		
	Impedance DC 0 / 4...20 mA	240 Ω / 5nF		
	Forced control ZC			
	Input impedance	22 k Ω		
	Close valve (ZC connected to G0)	< AC 1 V; < DC 0.8 V		
	Open valve (ZC connected to G)	> AC 6 V; > DC 5 V		
	No function (ZC not wired)	Positioning signal Y active		
Signal outputs	Position feedback signal U	Voltage	DC 0/2...10 V; load resistance \geq 500 Ω	
		Current	DC 0/4...20 mA; load resistance \leq 500 Ω	
	Stroke detection		Inductive	
	Nonlinearity		Accuracy \pm 3 % full scale	
Positioning time	Positioning time		< 1 s	
Electrical connections	Cable entry glands		3 x \varnothing 17 mm (for M16)	
	Min. wire cross-section		0.75 mm ²	
	Max. cable length		See «Connection type», page 5	
Product data valve	Permissible operating pressure		max. 4,5 MPa (45 bar) ¹⁾	
	Max. differential pressure Δp_{max}		2.5 MPa (25 bar)	
			DN32: 200 kPa (2 bar)	
	Valve characteristic (stroke, k_v)		Linear (to VDI / VDE 2173)	
	Leakage rate (internally across seat)			Max. 0.002% k_{vs} or
				Max. 1 NI/h gas at $\Delta p = 4$ bar
			Shut/off function, like solenoid normally closed (NC) function	

	External seal	Hermetically sealed (fully welded, no static or dynamic seals)
	Permissible media	Commonly used safety refrigerants (R22, R134a, R404A, R407C, R410A, R507 etc.) and R744 (CO ₂); Not suitable for flammable refrigerants ²⁾
	Medium temperature	-40...120 °C; max. 140 °C for 10 min
	Stroke resolution $\Delta H/H_{100}$	1 : 1000 (H = stroke)
	Hysteresis	Typically 3 %
	Mode of operation	Modulating
	Position when deenergized	Control path A → AB closed
	Orientation	Upright to horizontal ³⁾
Materials	Valve body and parts	Steel / CrNi steel
	Seat / piston	CrNi steel / brass
	Sealing disk	PTFE
Pipe connections	Sleeves	Internally soldered, CrNi steel
Dimensions and weight	Dimensions	See "Dimensions" page 11
	Weight	See "Dimensions" page 11
Standards	CE conformity	
	To EMC requirements	2004/108/EC
	Immunity	EN 61000-6-2:[2005] Industrial ⁴⁾
	Emission	EN 61000-6-3:[2007] Residential
	Electrical safety	EN 60730-1
	Protection class	Class III as per EN 60730
	Degree of pollution	Degree 2 as per EN 60730
	Housing protection	
	Upright to horizontal	IP65 as per EN 60529 ³⁾
	Vibration ⁵⁾	EN 60068-2-6 5 g acceleration, 10...150 Hz, 2.5 h (5 g horizontal, max. 2 g upright)
	Conformant to	UL standards CSA, Canada C-tick
		UL 873 C22.2 No. 24 N 474
	Environmental compatibility	ISO 14001 (environment) ISO 9001 (quality) SN 36350 (environmentally-compatible products) RL 2002/95/EG (RoHS)
	Permissible operating pressure	PED 97/23/EC
	Pressure accessories	As per article 1, section 2.1.4
	Fluid group 2	Without CE-marking as per article 3, section 3 (sound engineering practice)

¹⁾ To EN 12284 tested with 1,43 x operating pressure at 65 bar

²⁾ For flammable refrigerants use ATEX certified refrigerant valves (CDV..MVL..)

³⁾ At 45 °C < T_{amb} < 55 °C and 80 °C < T_{med} < 120 °C the valve must be installed on its side to avoid shortening the service life of the valve electronics

⁴⁾ Transformer 160 VA (e.g. Siemens 4AM 3842-4TN00-0EA0)

⁵⁾ In case of strong vibrations, use high-flex stranded wires for safety reasons.

General environmental conditions

	Operation EN 60721-3-3	Transport EN 60721-3-2	Storage EN 60721-3-1
Climatic conditions	Class 3K6	Class 2K3	Class 1K3
Temperature	-25...55 °C	-25...70 °C	-5...45 °C
Humidity	10...100% r. h.	< 95% r. h.	5...95% r. h.

Connection terminals

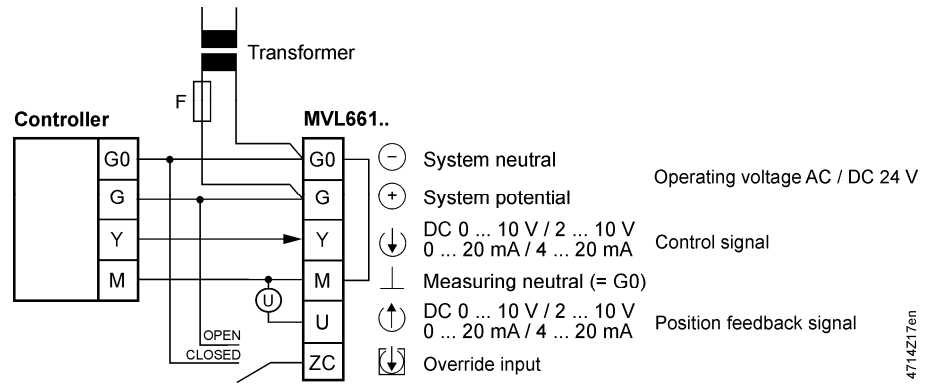

Connection diagrams

Terminal assignment for controller with 4-wire connection (to be preferred!)

Common transformer

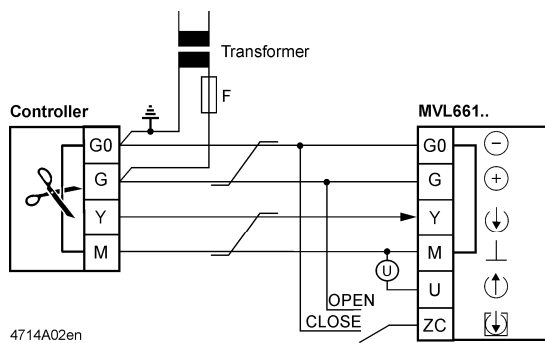

Separate transformer

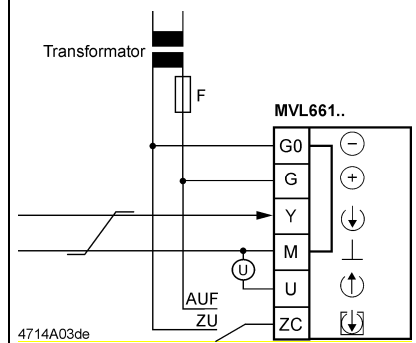

Terminal assignment for controller with 3-wire connection

Common transformer

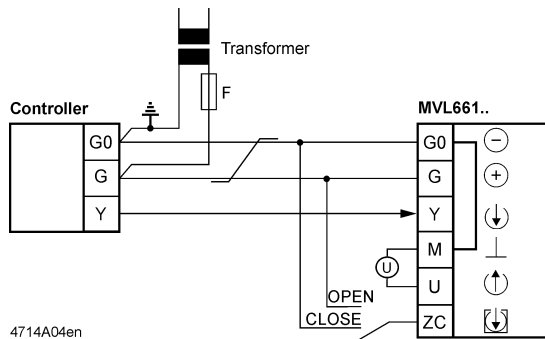

Separate transformer

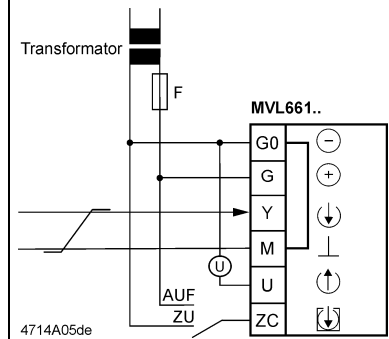

- Indication of valve position (only if required). DC 0...10 V → 0...100% volumetric flow V100
- Twisted pairs. If the lines for AC 24 V power supply and the DC 0...10 V (DC 2...10 V, DC 0...20 mA, DC 4...20 mA) positioning signal are routed separately, the AC 24 V line need not be twisted.

Warning

Piping must be connected to potential earth!

DIL switch

Factory setting: Valve characteristics equal-percentage, positioning signal DC 0...10 V. Details see "Configuration DIL switches", page 3.

Calibration

See "Calibration", page 4.

Dimensions

Dimensions in mm

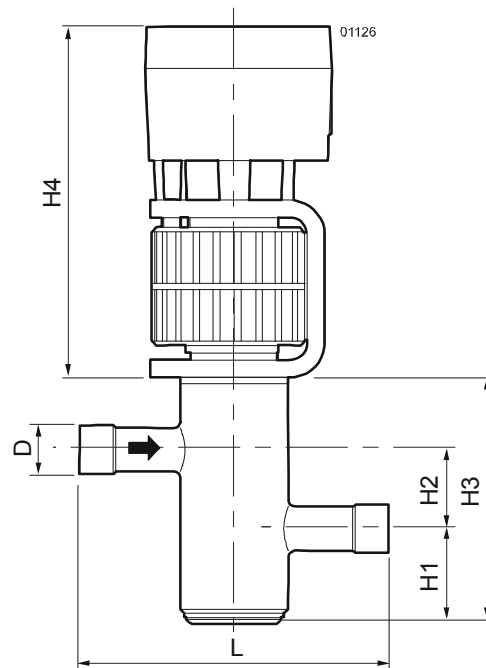

Type reference	DN	D [inch]	L [mm]	H1 [mm]	H2 [mm]	H3 [mm]	H4 [mm]	T [mm]	M [kg]
MVL661.15-0.4	15	5/8"	140	44	36	113	160	103	4.4
MVL661.15-1.0	15	5/8"	140	44	36	113	160	103	4.4
MVL661.20-2.5	20	7/8"	150	41	41	119	160	103	4.5
MVL661.25-6.3	25	1 1/8"	160	40	47	126	160	103	4.6
MVL661.32-12	32	1 3/8"	190	43	54	142	160	103	6.1

DN Nominal size
D Pipe connections [inch], internal dimension
T Depth
M Weight including packaging [kg]

Valve sizing with correction factor

The applications and tables on the following pages are designed for help with selecting the valves. To select the correct valve, the following data is required:

- **Application**
 - Expansion (starting on page 14)
 - Hot-gas (starting on page 16)
 - Suction throttle (starting on page 18)
- **Refrigerant type**
- **Evaporating temperature t_0 [°C]**
- **Condensing temperature t_c [°C]**
- **Refrigeration capacity Q_0 [kW]**

To calculate the nominal capacity, use the following formula:

- $k_{vs} \text{ [m}^3\text{/h]} = Q_0 \text{ [kW]} / K...^*$
 - * $K...$ for expansion = **KE**
 - for hot-gas = **KH**
 - for suction throttle = **KS**
- The theoretical kv value for the nominal refrigeration capacity of the plant should not be less than 50% of the kvs value of the selected valve.

- For accurate valve sizing, we recommend the valve selection program "Refrigeration VASP".

The application examples on the following pages deal with the principles only. They do not include installation-specific details such as safety elements, refrigerant collectors, etc.

Use of the MVL661... as an expansion valve

- Note
- Observe engineering notes page 6
 - Typical control range 20...100%.
 - Increased capacity through better use of the evaporator
 - The use of two or more compressors or compressor stages significantly increases efficiency with low loads
 - Especially suitable for fluctuating condensing and evaporating pressures

Capacity optimization

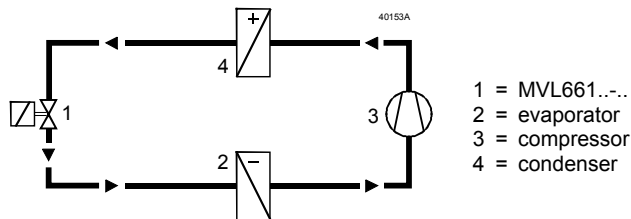

Electronic superheat control is achieved by using additional control equipment (e.g. PolyCool).

Application example

Refrigerant R407C; $Q_0 = 205 \text{ kW}$; $t_0 = -5 \text{ °C}$; $t_c = 35 \text{ °C}$

The correct k_{vs} value for the MVL661... valve needs to be determined.

The important section of table KE for R407C (see page 12) is the area around the working point. The correction factor KE relevant to the working point should be determined by linear interpolation from the four guide values.

Note on interpolation

In practice, the KE, KH or KS value can be estimated because the theoretical k_{vs} -value ascertained will be rounded off by up to 30% to one of the ten available k_{vs} -values, allowing you to proceed directly at Step 4.

- Step 1: For $t_c = 35$, calculate the value for $t_0 = -10$ between values 20 and 40 in the table; result: **112**
- Step 2: For $t_c = 35$, calculate the value for $t_0 = 0$ between values 20 and 40 in the table; result: **109**
- Step 3: For $t_0 = -5$, calculate the value for $t_c = 35$ between correction factors 112 and 109; calculated in steps 1 and 2; result: **111**
- Step 4: Calculate the theoretical k_{vs} value; result: **$1.85 \text{ m}^3/\text{h}$**
- Step 5: Select the valve; the valve closest to the theoretical k_{vs} value is the **MVL661.20-2.5**
- Step 6: Check that the theoretical k_{vs} value is not less than 50 % of the nominal k_{vs} value

KE-R407C	t ₀ = -10 °C	t ₀ = 0 °C
t _c = 20 °C	108	85
t _c = 35 °C	112	109
t _c = 40 °C	113	117

Interpolation at		t _c = 35 °C
108 + [(113 - 108) x (35 - 20) / (40 - 20)]		112
85 + [(117 - 85) x (35 - 20) / (40 - 20)]		109

Interpolation at		t ₀ = -5 °C
112 + [(109 - 112) x (-5 - 0) / (-10 - 0)]		111

k_v theoretical = 205 kW / 111 = 1.85 m³/h

Valve MVL661.20-2.5 is suitable, since: 1.85 m³/h / 2.5 m³/h x 100% = 74% (> 50%)

Capacity control

a) Refrigerant valve MVL661... for capacity control of a dry expansion evaporator.

Suction pressure and temperature are monitored with a mechanical capacity controller and reinjection valve.

- Typical control range 0...100%
- Energy-efficient operation with low loads
 - Ideal control of temperature and dehumidification

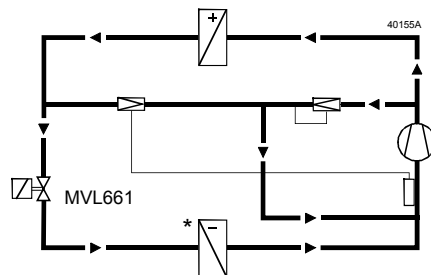

b) Refrigerant valve MVL661... for capacity control of a chiller.

- Typical control range 10...100%
- Energy-efficient operation with low loads
 - Allows wide adjustment of condensing and evaporating temperatures
 - Ideal for use with plate heat exchangers
 - Very high degree of frost protection

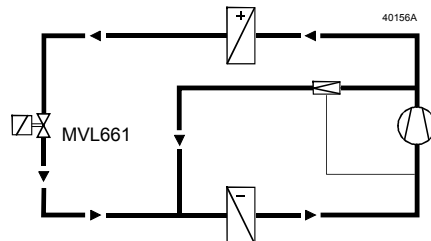

Note

A larger valve may be required for low load operation than is needed for full load conditions. To ensure that the selected valve will not be too small for low loads, sizing should take account of both possibilities.

Correction table KE

Expansion valve

$t_c \setminus t_o$	R22					
	-40	-30	-20	-10	0	10
00	82	68	37			
20	101	104	107	105	81	18
40	108	111	114	118	120	123
60	104	108	112	116	119	122

$t_c \setminus t_o$	R134a					
	-40	-30	-20	-10	0	10
00	27					
20	71	74	77	66	43	
40	74	78	81	85	89	92
60	67	72	76	81	85	89

$t_c \setminus t_o$	R744					
	-40	-30	-20	-10	0	10
-20	226	149				
00	262	264	241	166		
20	245	247	247	246	213	

$t_c \setminus t_o$	R401A					
	-40	-30	-20	-10	0	10
00	31					
20	80	83	85	72	46	
40	87	90	94	97	101	102
60	85	89	94	98	102	106

$t_c \setminus t_o$	R402A					
	-40	-30	-20	-10	0	10
00	73	69	50			
20	77	81	85	88	74	35
40	71	75	80	84	88	91
60	50	55	60	65	69	74

$t_c \setminus t_o$	R404A					
	-40	-30	-20	-10	0	10
00	69	63	44			
20	70	74	78	81	68	30
40	61	65	70	74	78	81
60	36	41	46	51	55	59

$t_c \setminus t_o$	R407A					
	-40	-30	-20	-10	0	10
00	79	67	40			
20	91	95	98	102	82	30
40	89	94	98	102	106	110
60	72	77	82	87	92	96

$t_c \setminus t_o$	R407B					
	-40	-30	-20	-10	0	10
00	72	66	45			
20	77	80	84	88	75	34
40	69	74	78	83	87	91
60	46	51	56	61	66	70

$t_c \setminus t_o$	R407C					
	-40	-30	-20	-10	0	10
00	79	65	31			
20	98	101	105	108	85	21
40	100	104	109	113	117	121
60	87	93	98	103	108	113

$t_c \setminus t_o$	R410A					
	-40	-30	-20	-10	0	10
00	116	117	91	12		
20	125	130	133	137	120	69
40	119	124	129	133	137	140
60	90	96	101	106	110	114

$t_c \setminus t_o$	R410B					
	-40	-30	-20	-10	0	10
00	112	112	87	11		
20	122	126	129	132	115	66
40	119	124	128	131	134	137
60	98	103	108	112	115	118

$t_c \setminus t_o$	R507					
	-40	-30	-20	-10	0	10
00	72	66	47			
20	78	81	83	86	71	33
40	74	78	81	84	87	90
60	53	57	61	64	68	71

- With superheat = 6 K
- Δp condenser = 0.3 bar
- With subcooling = 2 K
- Δp evaporator = 0.3 bar

Δp upstream of evaporator = 1.6 bar

The control valve throttles the capacity of a compressor stage. The hot gas passes directly to the evaporator, thus permitting capacity control in the range from 100% down to approximately 0%.

Indirect hot-gas bypass application

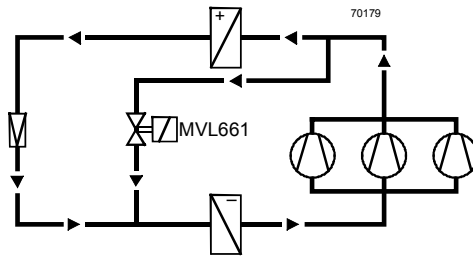

Suitable for use in large refrigeration systems in air conditioning plant, to prevent unacceptable temperature fluctuations between the compressor stages.

Application example

With low loads, the evaporating and condensing pressures can fluctuate depending on the type of pressure control. In such cases, evaporating pressure increases and condensing pressure decreases. Due to the reduction in differential pressure across the fully open valve, the volumetric flow rate will drop – the valve is undersized. This is why the effective pressures must be taken into account when sizing the valve for low loads.

Refrigerant R507; 3 compressor stages; $Q_0 = 75 \text{ kW}$; $t_0 = 4 \text{ °C}$; $t_c = 40 \text{ °C}$
 Part load Q_0 per stage = 28 kW ; $t_0 = 4 \text{ °C}$; $t_c = 23 \text{ °C}$

KH-R507	$t_0 = 0 \text{ °C}$	$t_0 = 10 \text{ °C}$
$t_c = 2 \text{ °C}$	14.4	9.0
$t_c = 23 \text{ °C}$	15.6	11.0
$t_c = 40 \text{ °C}$	22.4	22.0

Interpolation at	$t_c = 23 \text{ °C}$
$14.4 + [(22.4 - 14.4) \times (23 - 20) / (40 - 20)]$	15.6
$9.0 + [(22.0 - 9.0) \times (23 - 20) / (40 - 20)]$	11.0

Interpolation at	$t_0 = 4 \text{ °C}$
$15.6 + [(11.0 - 15.6) \times (4 - 0) / (10 - 0)]$	13.8

k_{vs} theoretical = $28 \text{ kW} / 13.8 = 2.03 \text{ m}^3/\text{h}$
 Valve MVL661.20-2.5 is suitable, since: $2.03 \text{ m}^3/\text{h} / 2.5 \text{ m}^3/\text{h} \times 100\% = 81\% (> 50\%)$

Direct hot-gas bypass application

The control valve throttles the capacity of one compressor stage. The gas is fed to the suction side of the compressor and then cooled using a reinjection valve. Capacity control ranges from 100% down to approximately 10%.

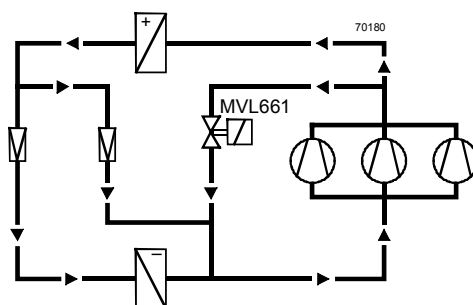

Suitable for large refrigeration systems in air conditioning applications with several compressors or compressor stages, and where the evaporator and compressor are some distance apart (attention must be paid to the oil return).

Correction table KH

Hot-gas valve

$t_c \setminus t_o$	R22					
	-40	-30	-20	-10	0	10
00	8.9	8.4	6.3			
20	15.3	15.1	14.8	14.6	13.2	6.5
40	24.2	23.7	23.2	22.8	22.4	22.1
60	35.7	34.7	33.8	33.0	32.3	31.7

$t_c \setminus t_o$	R134a					
	-40	-30	-20	-10	0	10
00	4.5					
20	9.8	9.6	9.5	9.2	7.4	
40	15.9	15.6	15.3	15.1	14.9	14.7
60	23.8	23.2	22.7	22.3	21.9	21.6

$t_c \setminus t_o$	R744					
	-40	-30	-20	-10	0	10
-20	38.1	30.5				
00	60.9	59.8	58.1	47.1		
20	87.3	84.9	82.5	80.2	76.1	

$t_c \setminus t_o$	R290					
	-40	-30	-20	-10	0	10
00	10.9	10.0	6.5			
20	18.0	17.7	17.4	17.1	15.0	
40	27.3	26.7	26.2	25.8	25.4	25.1
60	38.2	37.2	36.4	35.7	35.1	34.5

$t_c \setminus t_o$	R401A					
	-40	-30	-20	-10	0	10
00	4.7					
20	10.2	10.0	9.9	9.5	7.6	
40	16.9	16.6	16.2	16.0	15.8	15.6
60	25.9	25.2	24.6	24.1	23.7	23.3

$t_c \setminus t_o$	R402A					
	-40	-30	-20	-10	0	10
00	9.7	9.5	8.3			
20	15.9	15.7	15.4	15.2	14.5	9.3
40	23.7	23.2	22.7	22.4	22.0	21.7
60	31.5	30.7	29.9	29.2	28.7	28.1

$t_c \setminus t_o$	R404A					
	-40	-30	-20	-10	0	10
00	9.4	9.2	7.8			
20	15.2	15.0	14.8	14.6	13.9	8.6
40	22.3	21.8	21.5	21.1	20.9	20.6
60	28.8	28.0	27.4	26.8	26.4	25.9

$t_c \setminus t_o$	R407A					
	-40	-30	-20	-10	0	10
00	8.9	8.6	6.7			
20	15.7	15.4	15.2	15.0	14.1	8.0
40	24.9	24.4	23.9	23.5	23.1	22.8
60	35.9	34.9	34.0	33.2	32.6	32.0

$t_c \setminus t_o$	R407B					
	-40	-30	-20	-10	0	10
00	9.0	8.8	7.4			
20	15.3	15.1	14.8	14.7	14.0	8.8
40	23.3	22.8	22.4	22.0	21.7	21.5
60	31.6	30.7	30.0	29.3	28.8	28.3

$t_c \setminus t_o$	R407C					
	-40	-30	-20	-10	0	10
00	8.6	8.1	5.9			
20	15.3	15.0	14.8	14.6	13.6	7.0
40	24.7	24.2	23.7	23.3	22.9	22.6
60	36.3	35.3	34.4	33.6	33.0	32.4

$t_c \setminus t_o$	R410A					
	-40	-30	-20	-10	0	10
00	14.5	14.3	13.2	6.2		
20	24.2	23.7	23.3	23.0	22.1	15.9
40	36.8	35.9	35.1	34.4	33.7	33.1
60	50.0	48.5	47.2	46.0	44.9	43.8

$t_c \setminus t_o$	R410B					
	-40	-30	-20	-10	0	10
00	14.3	14.1	12.9	6.1		
20	23.8	23.3	22.9	22.5	21.6	15.5
40	36.5	35.6	34.7	33.9	33.2	32.5
60	50.7	49.1	47.7	46.4	45.2	44.0

$t_c \setminus t_o$	R507					
	-40	-30	-20	-10	0	10
00	9.8	9.5	8.1			
20	16.1	15.8	15.5	15.3	14.4	9.0
40	24.5	23.8	23.3	22.8	22.4	22.0
60	33.1	31.8	30.7	29.8	29.0	28.3

$t_c \setminus t_o$	R1270					
	-40	-30	-20	-10	0	10
00	13.5	13.0	10.3			
20	22.0	21.6	21.2	20.9	19.0	9.9
40	33.0	32.2	31.6	31.1	30.6	30.1
60	46.1	44.8	43.8	42.8	41.9	41.2

- With superheat = 6 K
- Δp condenser = 0.3 bar
- With subcooling = 2 K
- Δp evaporator = 0.3 bar

Δp upstream of evaporator = 1.6 bar

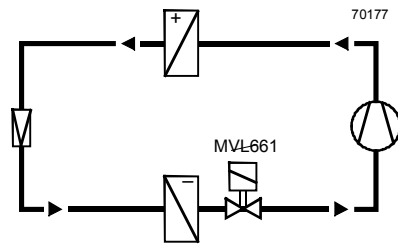

Typical control range 50...100%.

Minimum stroke limit control:

To ensure optimum cooling of the compressor, either a capacity controller must be provided for the compressor, or a minimum stroke must be set via the valve electronics.

The minimum stroke can be limited to a maximum of 80%. At zero load, the minimum stroke must be sufficient to ensure that the minimum gas velocity in the suction line is > 0.7 m/s and that the compressor is adequately cooled.

As the control valve closes, the evaporating temperature rises and the air cooling effect decreases continuously. The electronic control system provides demand-based cooling without unwanted dehumidification and costly retreatment of the air.

The pressure at the compressor inlet falls and the power consumption of the compressor is reduced. The energy savings to be anticipated with low loads can be determined from the compressor selection chart (power consumption at minimum permissible suction pressure). Compressor energy savings of up to 40% can be achieved.

The recommended differential pressure Δp_{v100} across the fully open control valve is between $0.15 < \Delta p_{v100} < 0.5$ bar.

Application example

Refrigerant R134A; $Q_0 = 9.5$ kW; $t_0 = 4$ °C; $t_c = 40$ °C;
Differential pressure across MVL661: $\Delta p_{v100} = 0.25$ bar

In this application example, t_0 , t_c and Δp_{v100} are to be interpolated.

KS-R134a	$t_0 = 0$ °C	$t_0 = 10$ °C
0.15 / 20	2.2	2.7
0.15 / 50	1.7	2.1
0.45 / 20	3.6	4.5
0.45 / 50	2.7	3.4

Interpolation at	$t_0 = 4$ °C
$2.2 + [(2.7 - 2.2) \times (4 - 0) / (10 - 0)]$	2.4
$1.7 + [(2.1 - 1.7) \times (4 - 0) / (10 - 0)]$	1.9
$3.6 + [(4.5 - 3.6) \times (4 - 0) / (10 - 0)]$	4.0
$2.7 + [(3.4 - 2.7) \times (4 - 0) / (10 - 0)]$	3.0

$t_0 = 4$ °C	$t_c = 20$ °C	$t_c = 50$ °C
$\Delta p_{v100} 0.15$	2.4	1.9
$\Delta p_{v100} 0.45$	4.0	3.0

Interpolation at	$t_c = 40$ °C
$2.4 + [(1.9 - 2.4) \times (40 - 20) / (50 - 20)]$	2.1
$4.0 + [(3.0 - 4.0) \times (40 - 20) / (50 - 20)]$	3.3

$t_c = 40$ °C	$\Delta p_{v100} 0.15$	$\Delta p_{v100} 0.45$
	2.1	3.3

Interpolation at	$\Delta p_{v100} 0.25$
$2.1 + [(3.3 - 2.1) \times (0.25 - 0.15) / (0.45 - 0.15)]$	2.5

k_{vs} theoretical = 9.5 kW / $2.5 = 3.8$ m³/h

Valve MVL661.25-6.3 is suitable, since 3.8 m³/h / 6.3 m³/h x 10 % = 60% (> 50%)

It is recommended that the k_{vs} value be set to 63% = 4 m³/h

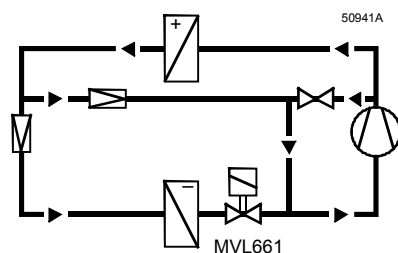

Typical control range 10...100%.

The capacity controller ensures that the compressor is adequately cooled, making it unnecessary to set a minimum stroke in the refrigerant valve.

Correction table KS
Suction throttle valve

t_c	R22					
	$\Delta p_{v100} \setminus t_o$	-40	-30	-20	-10	0
0.15 / 20	1.2	1.5	1.9	2.4	2.9	3.4
0.15 / 50	0.9	1.2	1.5	1.9	2.3	2.7
0.45 / 20	1.5	2.3	3.0	3.9	4.8	5.7
0.45 / 50	1.2	1.8	2.4	3.0	3.8	4.6

t_c	R134a					
	$\Delta p_{v100} \setminus t_o$	-40	-30	-20	-10	0
0.15 / 20	0.7	1.0	1.4	1.8	2.2	2.7
0.15 / 50	0.5	0.7	1.0	1.3	1.7	2.1
0.45 / 20	0.7	1.2	1.9	2.7	3.6	4.5
0.45 / 50	0.5	0.9	1.4	2.0	2.7	3.4

t_c	R152A					
	$\Delta p_{v100} \setminus t_o$	-40	-30	-20	-10	0
0.15 / 20	0.9	1.3	1.7	2.2	2.7	3.3
0.15 / 50	0.7	1.0	1.4	1.7	2.2	2.7
0.45 / 20	1.0	1.5	2.4	3.3	4.3	5.3
0.45 / 50	0.7	1.2	1.9	2.6	3.5	4.4

t_c	R290					
	$\Delta p_{v100} \setminus t_o$	-40	-30	-20	-10	0
0.15 / 20	1.5	1.9	2.4	3.0	3.6	4.3
0.15 / 50	1.0	1.4	1.8	2.2	2.7	3.3
0.45 / 20	2.0	2.8	3.8	4.8	6.0	7.2
0.45 / 50	1.4	2.1	2.8	3.6	4.5	5.5

t_c	R401A					
	$\Delta p_{v100} \setminus t_o$	-40	-30	-20	-10	0
0.15 / 20	0.8	1.1	1.5	1.9	2.3	2.9
0.15 / 50	0.6	0.8	1.1	1.5	1.8	2.3
0.45 / 20	0.8	1.3	2.1	2.9	3.7	4.7
0.45 / 50	0.6	1.0	1.6	2.3	3.0	3.7

t_c	R402A					
	$\Delta p_{v100} \setminus t_o$	-40	-30	-20	-10	0
0.15 / 20	1.1	1.4	1.8	2.2	2.7	3.3
0.15 / 50	0.7	0.9	1.2	1.5	1.8	2.3
0.45 / 20	1.5	2.2	2.9	3.7	4.6	5.6
0.45 / 50	0.9	1.4	1.9	2.4	3.1	3.8

t_c	R404A					
	$\Delta p_{v100} \setminus t_o$	-40	-30	-20	-10	0
0.15 / 20	1.0	1.3	1.7	2.2	2.7	3.3
0.15 / 50	0.6	0.8	1.1	1.4	1.7	2.1
0.45 / 20	1.4	2.1	2.8	3.6	4.5	5.5
0.45 / 50	0.8	1.2	1.7	2.3	2.9	3.6

t_c	R407A					
	$\Delta p_{v100} \setminus t_o$	-40	-30	-20	-10	0
0.15 / 20	1.0	1.4	1.8	2.3	2.9	3.5
0.15 / 50	0.7	1.0	1.3	1.6	2.1	2.6
0.45 / 20	1.3	2.0	2.9	3.8	4.7	5.9
0.45 / 50	0.9	1.4	2.0	2.7	3.4	4.3

t_c	R407B					
	$\Delta p_{v100} \setminus t_o$	-40	-30	-20	-10	0
0.15 / 20	1.0	1.3	1.7	2.2	2.7	3.3
0.15 / 50	0.6	0.8	1.1	1.4	1.8	2.2
0.45 / 20	1.3	2.0	2.7	3.5	4.5	5.5
0.45 / 50	0.8	1.2	1.7	2.3	3.0	3.8

t_c	R407C					
	$\Delta p_{v100} \setminus t_o$	-40	-30	-20	-10	0
0.15 / 20	1.0	1.4	1.8	2.3	2.9	3.5
0.15 / 50	0.7	1.0	1.3	1.7	2.1	2.6
0.45 / 20	1.3	2.0	2.8	3.8	4.8	5.9
0.45 / 50	0.9	1.4	2.1	2.8	3.5	4.4

t_c	R410A					
	$\Delta p_{v100} \setminus t_o$	-40	-30	-20	-10	0
0.15 / 20	1.5	2.0	2.5	3.0	3.6	4.4
0.15 / 50	1.0	1.3	1.7	2.1	2.6	3.1
0.45 / 20	2.3	3.1	4.0	5.0	6.1	7.4
0.45 / 50	1.6	2.1	2.8	3.5	4.4	5.3

t_c	R410B					
	$\Delta p_{v100} \setminus t_o$	-40	-30	-20	-10	0
0.15 / 20	1.5	1.9	2.4	2.9	3.6	4.2
0.15 / 50	1.0	1.3	1.7	2.1	2.6	3.1
0.45 / 20	2.3	3.1	3.9	4.9	6.0	7.2
0.45 / 50	1.6	2.1	2.8	3.5	4.3	5.2

- With superheat = 6 K
- Δp condenser = 0.3 bar
- With subcooling = 2 K
- Δp evaporator = 0.3 bar
- Δp upstream of evaporator = 1.6 bar

Revision numbers

Product number	Valid from rev. no.
MVL661.15-0.4	C
MVL661.15-1.0	C
MVL661.20-2.5	D
MVL661.25-6.3	C
MVL661.32-12	C

