

DESIGO™ RXA

Non-communicating room controllers

RXA29.1

For fan-coil systems

The RXA29.1 room controller are used for temperature control in individual rooms.

- For 2-pipe or 4-pipe fan-coil systems, with or without changeover
- Control of AC 24 V PWM ¹⁾ thermic valve actuators, 3-position AC 24 V valve and damper actuators
- PI control
- AC 230 V operating voltage

1) PWM = pulse-width modulated

Use

The RXA29.1 room controller is optimised for control of fan-coil systems in individual rooms.

Functions

The controller application and the configuration of connected field devices are defined manually with DIP switches and a potentiometer.

For a detailed description of functions, refer to the DESIGO RXA applications library, document CA2A3886.

Types

Type	AC 24 V triac outputs	Relay outputs
RXA29.1/FC-04	For two thermic valve actuators or two 3-position actuators	None
RXZ20.1	Accessories: terminal covers	

Ordering

When ordering, please specify the quantity, product name and type code. The RXZ20.1 terminal covers are supplied in packs of 10 pairs and must be ordered as a separate item (see also "Mounting").

Example:

30	Room controllers, type RXA29.1	RXA29.1/FC-04
30	Pairs of terminal covers	RXZ20.1

Compatibility

The QAA24 and QAA27 room temperature sensors and the Siemens field devices are suitable for use with the RXA29.1 room controller.

For details, refer to the product range description, document CA2S3880.

The RXA29.1 room controller consists of a housing base, a housing cover and the printed circuit board. The printed circuit board incorporates the connection terminals and the DIP switches used for configuration. The controllers also have a potentiometer for setpoint adjustment and testing, and a Service LED with different flashing patterns to indicate operational status and test states.

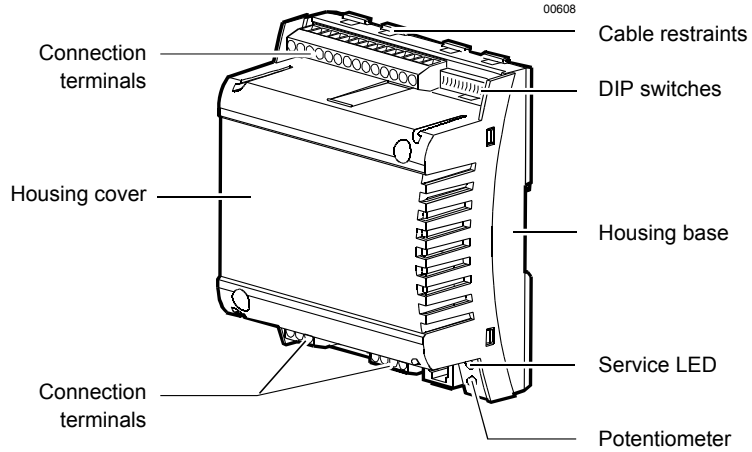

Terminal cover

Terminal covers (RXZ20.1) are available as an option, to protect the connection terminals from physical contact and dirt. The Service LED and the potentiometer remain visible even with the terminal covers fitted. The potentiometer can be operated with a screwdriver. The cable is connected to the room controller by breaking out the perforated cable entry guide.

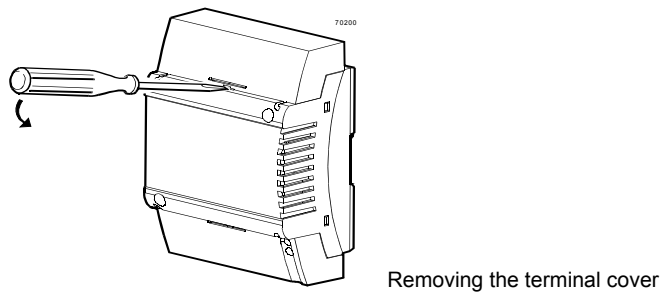

Label

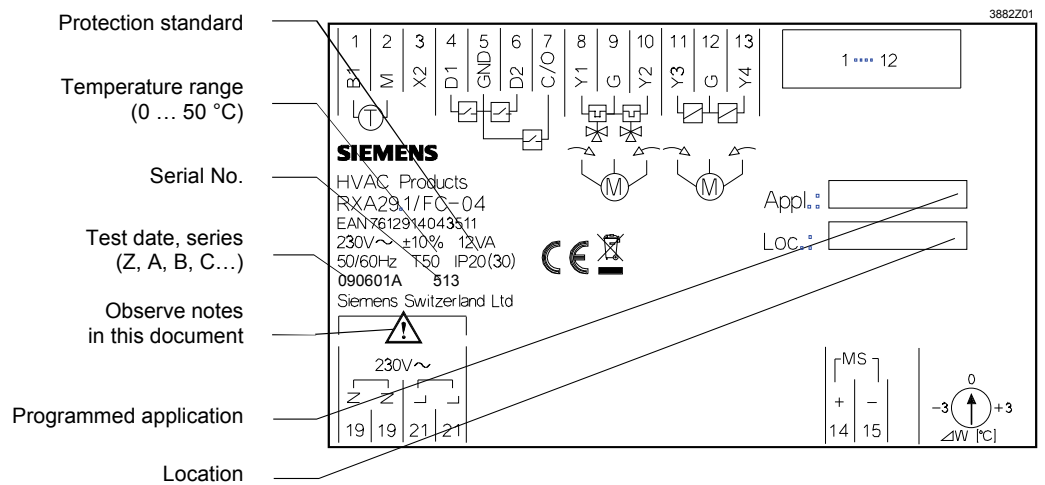

Note

Options for use of the labeling fields “Appl.” and “Loc.”:

- Handwritten entry of location and the final application or
- Printed adhesive label

Connection terminals

To avoid incorrect wiring, terminals which can be connected to AC 230 V (supply and relay outputs) are physically separate from the other terminals.



Caution

The cable restraints on the housing base *must* be used for the connections to terminals 19 ... 28 (AC 230 V). The conductors must be secured with cable ties (see diagram).

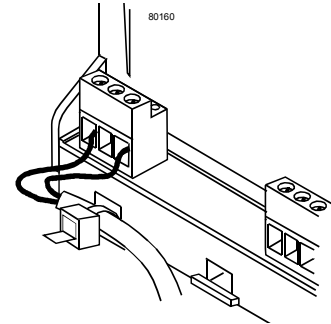

Disposal



The device is classified as waste electronic equipment in terms of the European Directive 2002/96/EC (WEEE) and should not be disposed of as unsorted municipal waste. The relevant national legal rules are to be adhered to.

Regarding disposal, use the systems setup for collecting electronic waste. Observe all local and applicable laws.

Engineering

For information on selecting and sizing the cables for the power supply and for the field devices, refer to the installation guide, document CA2Z3884. The room controllers have an AC 230 V mains supply voltage. The controlled devices (valves and damper actuators) are supplied directly from the room controller. This means that a separate AC 24 V supply is not necessary for the RXA29.1 controller and the associated field devices.

Master/slave

- Where several room controllers are operating in the same space, they must be synchronized via the master/slave interface.
- Up to 3 slaves may be used (operating in parallel).
- The outputs of the master controller are mapped in the slaves. Note that room units connected to a slave controller cannot be operated.
- The polarity of the M/S wires has to be respected!
- The master/slave interface is compatible with the PRFA and PRFB controllers in the PRONTO range.

AC 230 V supply cables

Sizing and fuse protection of the supply cables depends on the total load and on local regulations. The cables must be secured with cable restraints.

AC 24 V triac outputs

The **simultaneous** load on outputs Y1 ... Y4 must not exceed 9.5 VA.

Example:

Y1 (heating)	2 thermic valve actuators, type STP72E	6 W
Y2 (cooling)	2 thermic valve actuators, type STP72E	6 W
Y3, Y4 (outside air)	Damper actuator	3.5 VA

The maximum load is 9.5 VA for the heating sequence and 9.5 VA for the cooling sequence. This is acceptable because the two sequences never operate at the same time.

Mounting instructions

The room controllers can be mounted in any orientation using the following fixing options:

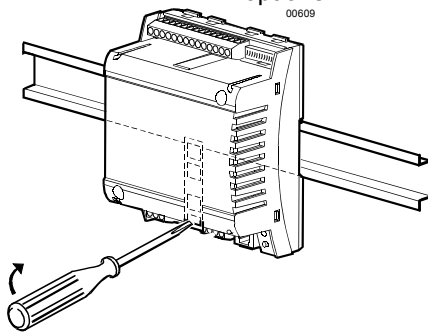

Rail mounting

The housing base is designed for snap-mounting on DIN rails, type EN50022-35x7.5 (can be released with a screwdriver)

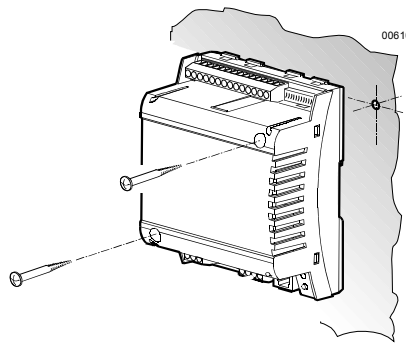

Surface mounting

There are two drill holes for screw-mounting (see "Dimensions" for drilling template). The housing base is fitted with raised supports. Screws: Max. diameter 3.5 mm, min. length 38 mm



Note!

Tightening torque for fixing screws max. 1.5 Nm

When mounting note the following:

- The controller should not be freely accessible after mounting
- Ensure adequate air circulation to dissipate heat generated during operation.
- Easy access is required for service personnel
- Local installation regulations must be observed.

Mounting instructions and a drilling template are printed on the controller packaging.

Commissioning

The controller application and the configuration of the connected field devices are defined manually with DIP switches and the potentiometer. The Service LED provides information on power up and operational status.

There is no special test for checking that the connected field devices match the DIP switch settings. Depending on the application, if the controller has insufficient information it switches to "Idle" mode (all outputs at zero) and the LED remains on continuously.

For details refer to the applications library CA2A3886.





Caution

In the event of a long-term short circuit or overload, the thermal fuse in the transformer may trip. The controller must then be replaced.

There is no protection against accidental connection with 230 V on the AC 24 V side.

Technical data

Power supply	Operating voltage	AC 230 V ± 10 %	
	Rated voltage	AC 230 V	
	Frequency	50/60 Hz	
	Power consumption with output field devices connected	Max. 12 VA	
Operating data Inputs	Internal fuse	Thermal, non-resetting	
	Control algorithm	PI	
	Signal inputs D1 ... D3 (for volt-free contacts)		
	Quantity	3	
	Contact voltage	DC 16 V	
	Contact current	DC 8 mA	
	Contact transfer resistance	Max. 100 Ω	
	Contact insulation resistance	Min. 50 kΩ	
	Not suitable for pulse control		
	Measured value inputs B1 and B2		
	Type of signal is programmable (DIP switch)	LG-Ni 1000 temperature sensor or setpoint adjuster	
	Temperature sensor	LG-Ni 1000	
	Measuring range	0 ... 50 °C	
	Sensor current	2.3 mA	
	Resolution	0.2 K	
	Measuring error at 25 °C sensor temp. (without cable)	Max. 0.2 K	
	Setpoint adjuster	BSGN-U1	
Reset range	+/- 3K		
Outputs	AC24 V triac outputs , Y1 ... Y4		
	Quantity	4	
	Output voltage (SELV, not earthed)	AC 24 V ON/OFF, PWM or 3-position (depending on application)	
	Output current	Max. 0.5 A	
	Total nominal load (at both outputs simultaneously)	Max. 9.5 VA (e.g. 2 thermic valves, type STE72 per heating and cooling sequence + 1 damper actuator 3.5 VA)	
Interfaces	Master/slave interface	Proprietary	
	Max. number of slaves	3	
Cable connections	Connection terminals for signals and power supply (screw terminals)	Stranded or solid conductors, 0.25 ... 2.5 mm ² or (solid conductors only) 2 x 1.5 mm ²	
Single cable lengths	Signal inputs D1... D3	Max. 100 m with diameters ≥ 0.6 mm	
	Measured value inputs B1 and B2	Max. 100m where A ≥ 1.5 mm ²	
	AC24 V triac outputs , Y1 ... Y4	Max. 100m where A ≥ 1.5 mm ²	
	Interface to slaves	Max. 50 m where A = 0.75 mm ²	
Housing protection standard	Cable type	2-core, twisted pair, unshielded	
	Protection standard to EN 60529	IP30 with terminal cover fitted and wall mounted without DIN rail IP20 for all other mounting arrangements	
Protection class	Suitable for use in systems with protection class I or II		
Ambient conditions	Operation	Transport	
	Class	3K5 to IEC 60721-3-3	Class 2K3 to IEC 60721-3-2
	Temperature	0 ... 50 °C	- 25 ... 65 °C
	Humidity	< 85 % rh	< 95 % rh
Standards and directives	Product safety		
	Automatic electronic controls for household and similar use	EN 60730-1	
	Electromagnetic compatibility		
	Immunity (industrial & domestic)	EN 60730-1	
	Emissions (domestic)	EN 60730-1	
	 compliance		
	Meets requirements of EMC Directive	2004/108/EC	
	Low Voltage Directive	2006/95/EC	
	 C-Tick conformity (EMC)	AS/NZS 61000-6-3	
	 Reduktion gefährlicher Substanzen	2002/95/EG	
Dimensions	See dimension diagrams		
Weight	Excluding packaging 0.59 kg		

RXA29.1

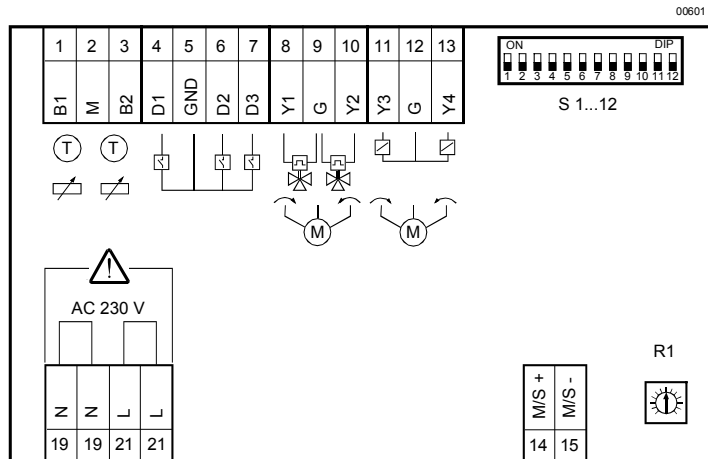

Measured value inputs

- B1 1 Measured value input for LG-Ni 1000 sensor or setpoint adjuster
- M 2 Measured value input ground
- B2 3 Measured value input for LG-Ni 1000 sensor or setpoint adjuster

Signal inputs

- D1 4 Signal input (window or clock)
- GND 5 Signal ground
- D2 6 Signal input (occupancy)
- D3 7 Changeover input

Triac outputs

- Y1 8 AC 24 V, 0.5 A switching output
- G 9 AC 24 V actuator supply
- Y2 10 AC 24 V, 0.5 A switching output
- Y3 11 AC 24 V, 0.5 A switching output
- G 12 AC 24 V actuator supply
- Y4 13 AC 24 V, 0.5 A switching output

Master / Slave interface

- M/S+ 14/15 Master/slave connection

Power supply

- N 19 Neutral conductor
- L 21 Phase conductor AC 230 V +/- 10 %

Operator controls

- S1...12 DIP switch for configuring the room controller.
- R1 Potentiometer for setpoint reset and test purposes.



Caution!

Local installation regulations must be observed.

Connecting the field devices, room units and supply voltage

00603 b

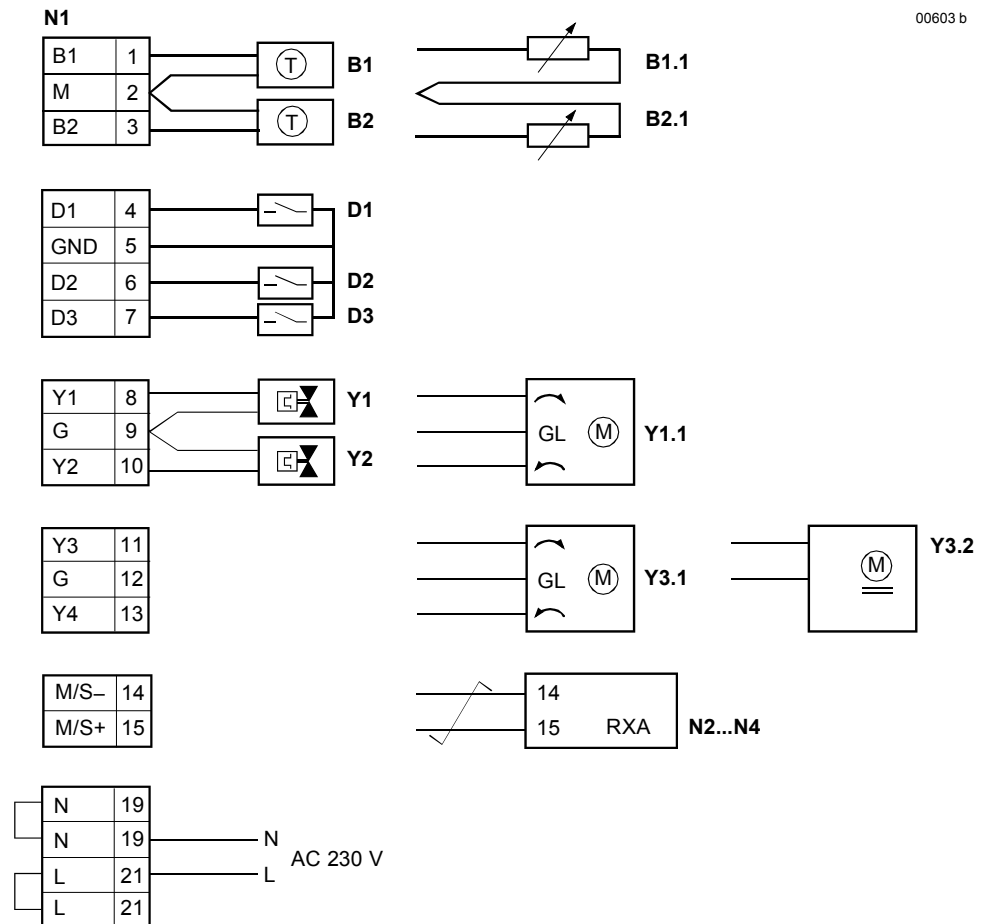

- N1 RXA29.1
- N2...N4 Max. 3 slave controllers
- B1, B2 LG-Ni 1000 temperature sensor
- B1.1, B2.1 Setpoint adjuster
- D1, D2 Volt-free contacts (window contact, occupancy sensor, central time switch etc.)
- D3 Changeover signal
- Y1, Y2 AC 24 V thermic valve actuators
- Y1.1, Y3.1 Valve actuator, AC 24 V, 3-position (RXA21.1 only)
- Y3.2 Damper actuator with spring return

 Twisted pair

Note

For information on the compatibility of the various field devices with the RXA29.1 room controller, refer to the relevant application description.

Connecting a power amplifier

Parallel connection of a number of thermic valve actuators to output Y1 using the UA1T power amplifier.

The same principle applies to outputs Y2 ... Y4. Note that the simultaneous load on outputs Y1 ... Y4 must not exceed 9.5 VA (power consumption at input X1 of the UA1T: 0.5 VA)

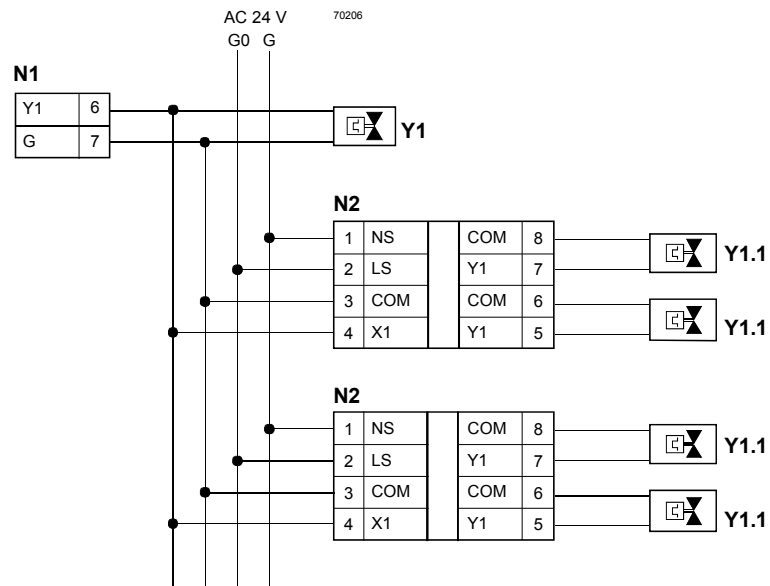

N1	RXA29.1
N2	UA1T (see data sheet CA2N3591)
Y1	AC 24 V thermic valve actuator
Y1.1	AC 24 V thermic valve actuator (max. 2 STP72E actuators per Y1 output on the UA1T)

Notes

- The UA1T requires an AC 24 V supply voltage
- The UA1T is *not* suitable for the connection of 3-position actuators.

Dimensions

Without terminal covers

Dimensions in mm

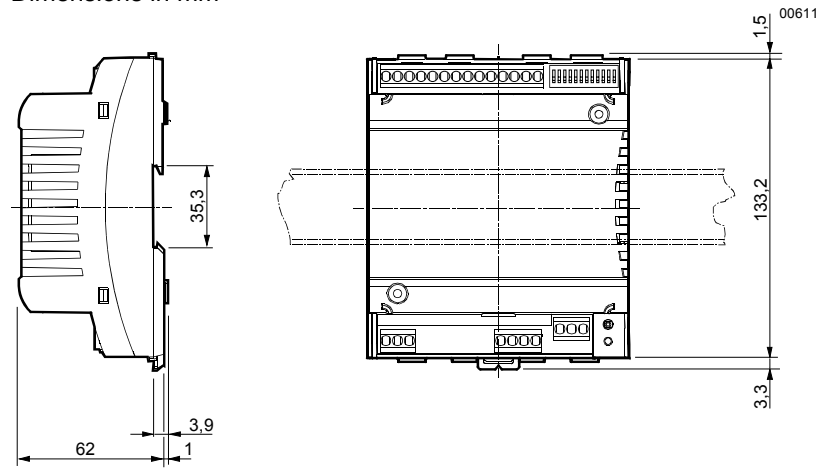

With terminal covers

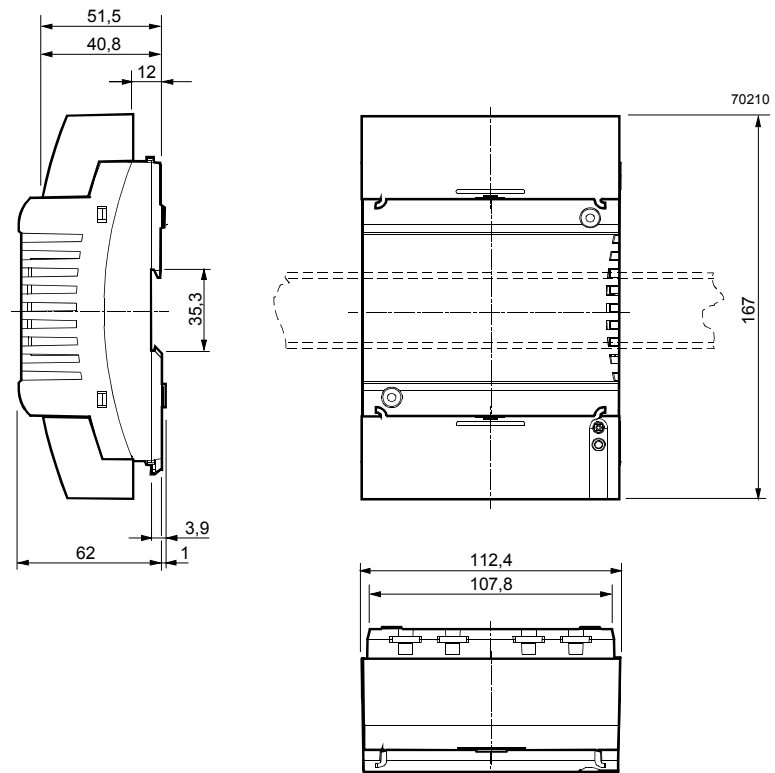

Drilling diagram

