

DESIGO™ RXC

## Room controller

# RXC32.1

for VAV systems,  
with LONMARK-compatible bus communication

The RXC32.1 controller is used for VAV room temperature control in individual rooms.

- Control of the supply or extract air with volume control dampers, with or without reheaters
- Downloadable application software
- LONMARK-compatible bus communications
- For use in the DESIGO building automation and control system
- Control of damper actuators with AC 24 V, 3-position signal
- Control of electric or LPHW reheaters with AC 24 V or AC 24 V 3-position signals
- Built-in air flow sensor
- AC 24 V operating voltage

### Application

The RXC32.1 controller is optimised for the control of variable air volume (VAV) systems. It is designed for control of the supply or extract air with volume control dampers. The controller may also be used for the control of electric or LPHW reheaters.

The controller application is determined by downloadable application software, also referred to simply as the “application”. The various applications and the associated functions are described in detail in the applications library (V1: CA2A3810, V2: CA110300).

The controllers are delivered pre-loaded with a particular application or with basic application 00032. The basic application, which contains only I/O module functions, is overwritten with the definitive application in the commissioning phase. The RXT10 commissioning and service tool is used for this purpose (see "Commissioning").

### Use as an I/O module

In conjunction with a building automation and control system, the RXC32.1 controller can also be used as a universal I/O module, e.g. to register digital signals or to control various equipment (ON/OFF or pulse control with AC 24 V). In this case the controller is loaded with basic application 00032. The inputs can then be read and the outputs overridden via the building automation and control system.

### Functions

---

The controller functions are determined by the selected application and its parameters. For a detailed description of functions, refer to the DESIGO RXC applications library (V1: CA2A3810, V2: CA110300).

### Inputs and outputs

Certain input and output parameters can be set for various functions making it possible to cover a wide range of VAV systems. (For parameter settings for the various applications, refer to the DESIGO RXC applications library (V1: CA2A3810, V2: CA110300).

Input	Function
D1	- Occupancy sensor (volt-free contact)
D2	- Window switch (volt-free contact)
X1	- LG-Ni 1000 temperature sensor (passive) - Air quality sensor (DC 0 ... 10 V)

Output	Function
Y1 and Y2	- 3-position damper actuators (AC 24 V)
Y3	- Radiator with thermic valve (AC 24 V, PDM)
Y4	- Electric reheater (AC 24 V, on/off)
Y3 and Y4	- LPHW reheater with motorised valve (AC 24 V, 3-position)

### Integration into the building automation and control system

When DESIGO RXC is integrated into a building automation and control system additional functions become available such as time scheduling, central control of setpoints, etc. (refer to the DESIGO INSIGHT documentation for further information).

### Types

---

<b>RXC32.1</b>	Room controller for VAV systems
<b>RXZ30.1</b>	Accessories: Terminal covers

### Ordering

---

When ordering please specify the quantity, product name and type code. The controllers will be delivered with basic application 00032.

The RXZ30.1 terminal covers are supplied in packs of 10 pairs and must be ordered separately).

*Example:*

<b>30</b>	<b>Room controllers for VAV systems</b>	<b>RXC32.1/00032</b>
<b>30</b>	<b>Pairs of terminal covers</b>	<b>RXZ30.1</b>

## Compatibility

For operation of the RXC32.1 room controller, a room unit from the QAX... series may be used in conjunction with conventional momentary contact switches for lighting and blind control. Alternatively, the flexible room units, QAX50.1 or QAX51.1 may be used. See the RX hardware overview (CA2N3804) for a summary of the available field devices.

## Mechanical design

The RXC32.1 controller consists of a housing base, a housing cover and the printed circuit board with connection terminals. The controller also has a tool socket, a service LED and a service pin.

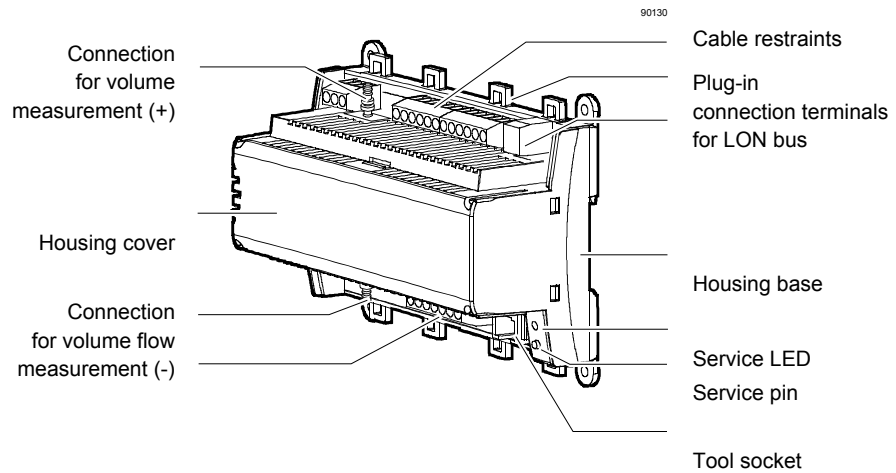

## Terminal covers

Terminal covers (RXZ30.1) are available as an option to protect the connection terminals from physical contact and contamination. The terminal covers also provide strain relief for the cables. The service LED remains visible when the terminal covers are in place, and the service pin can be operated with a pointed implement. When fitting the terminal covers ensure that they lock into place.

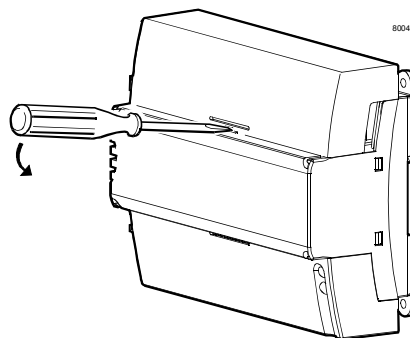

Removing the terminal cover

## Label

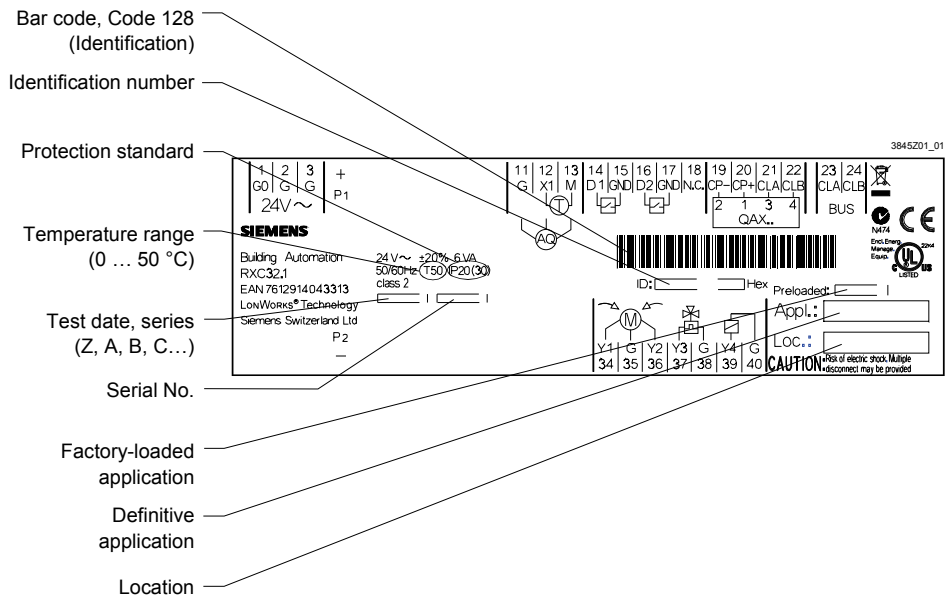

- Note** Options for use of the labeling fields “Appl.” and “Loc.”:
- Hand-written entry of the location and the actual application... or
  - Printed adhesive label (printed from the RXT10 commissioning and service tool)

## Connection terminals

All connection terminals are detachable plug-in terminals. They are arranged so that, under normal circumstances, all incoming and outgoing cables can be connected without crossing.

## Cable strain relief

The conductors to the connection terminals can be secured with cable ties to the housing base.

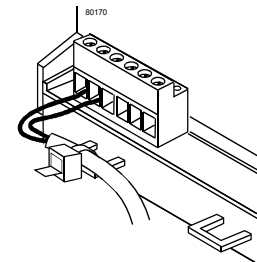

## Flow sensor

The flow sensor uses an NTC thermistor to measure the cooling effect of the air flowing through the sensor. A second thermistor is used for air temperature compensation. From the sensor signal the controller processor calculates the air volume flowing through the VAV box.

## Communication

The RXC32.1 controller communicates with other devices via the following interfaces:

- LON bus (terminals CLA and CLB) for communication with:
  - the PXR system controller or the NIDES.RX interface (to DESIGO)
  - other DESIGO RXC devices
  - LONMARK-compatible 3<sup>rd</sup> party devices (e.g. presence detector)
- PPS2 (terminals CP- and CP+):
  - Interface to the QAX... room units. (In addition to PPS2, the LON bus is also looped to the tool socket on the room unit.)
- Tool socket (RJ45) on the controller or room unit, for:
  - RXT10 commissioning and service tool (LON bus)
  - RXT20.1 service terminal (PPS2)

The diagram below shows the wiring of the LON bus and PPS2 interface when a QAX... room unit is connected. It also shows the options for connecting the RXT10 commissioning and service tool and the RXT20.1 service terminal.

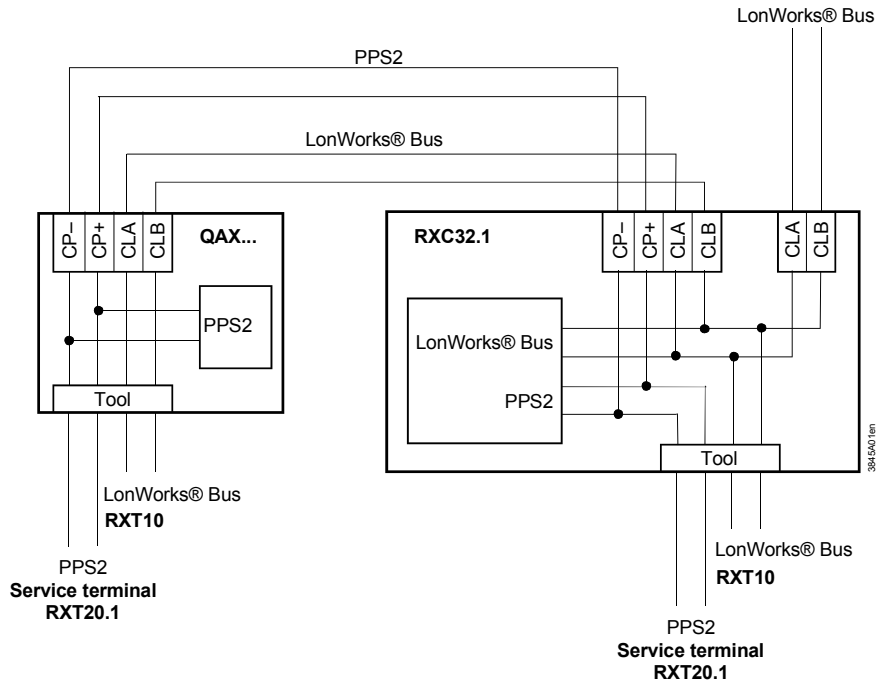

**Service LED**

The yellow service LED shows the current operational status of the controller by means of different flashing patterns (see the RXT10 user manual, CA110338).

**Service pin**

The service pin is used to identify the controller in the commissioning phase. When the pin is pressed the controller’s identification number is transmitted to the RXT10 commissioning and service tool.

**Disposal**



The devices are classified as waste electronic equipment in terms of the European Directive 2002/96/EC (WEEE) and should not be disposed of as unsorted municipal waste. The relevant national legal rules are to be adhered to. Regarding disposal, use the systems setup for collecting electronic waste. Observe all local and applicable laws.

**Engineering notes**

The DESIGO RXC installation guide, document CA110334, contains the relevant engineering information for the LON bus (topology, bus repeaters, bus termination, etc.) and for the selection and dimensions of connecting cables for the supply voltage and field devices. See “Connection diagrams” for information on connecting field devices.

**AC 24 V supply**

The controller operates with an AC 24 V supply voltage (SELV / PELV). The supply cable must be protected with at least 10 A. The controlled devices (valves and damper actuators) are supplied directly from the controller. The maximum load on the outputs must not be exceeded (see “Technical data”). The power consumption of the connected devices must be taken into account when sizing the transformer.

## AC 24 V triac outputs

- The **simultaneous** load on outputs Y3... Y6 must not exceed 24 VA.
- The maximum load on each output must not exceed 12 VA.

### Example

Equipment	Y1, Y2	1 3-position motorised actuator GDB...1E	2 VA
	Y3 (Cooling)	2 thermic valve actuators, type STP72E	6 W
	Y4 (Heating)	2 thermic valve actuators, type STP72E	6 W
Simultaneous load:	2 motorised actuators (both ON continuously)		4 VA
	2 thermic valve actuators *		<u>6 W (12 W) **</u>
			10 W (16 W)

\* The heating and cooling sequences are never operative simultaneously. Therefore, only the actuators for one of the two sequences need to be included when calculating the total load.

\*\* When cold, thermic valve actuators have a consumption of approximately 6 W. A maximum of two thermic actuators may be connected to any one Y... output.

## Mounting

The controller can be mounted in any orientation as follows:

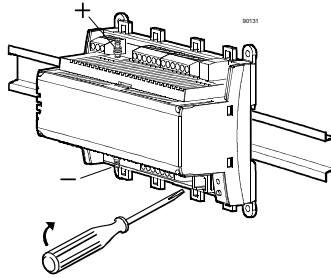

### Rail mounting

The housing base is designed for snap-mounting on DIN rails, type EN50022-35x7.5 (can be released with a screwdriver)

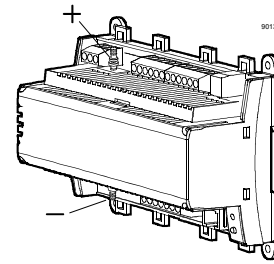

### Surface mounting

There are four drill holes for screw mounting (see "Dimensions" for drilling diagram). The housing base is fitted with raised supports.

Screws: Max. diameter 3.5 mm

When mounting note the following:

- Ensure adequate air circulation to dissipate heat generated during operation.
- Easy access is required for service personnel.
- Local installation regulations must be observed.

The mounting instructions and a drilling template are printed on the controller packaging.

### Connection, flow sensor

- Avoid bends and constrictions when connecting the tubing
- Connect the "+" connection to the higher pressure side and the "-" connection to the lower pressure side.
- The recommended tube length is in the range 700 mm ... 2 000 mm
- When using an air filter, install it on the high pressure side ("+"), with the air flowing through the filter in the correct direction.
- Use an air filter to prevent the accumulation of dirt particle deposits on the sensor element, especially when the extract air is contaminated (see technical data).

The RXC32.1 controller is commissioned with the RXT10 commissioning and service tool. This is connected to the LON bus via a tool socket (on the controller or room unit). The commissioning procedure for the entire DESIGO RXC range is described in detail in the RXT10 user manual, document CA110338.

### Labelling

The labelling fields “Appl.” and “Loc.” on the controller are used to indicate the application actually loaded and the location of the controller, either in writing or by use of printed adhesive labels (see “Label” under “Mechanical design”).

### Function test

All applications (including basic application 00032) allow direct interrogation of the inputs and control of the outputs using the RXT10 commissioning and service tool. This makes it possible to test the installation and to operate connected plant provisionally before the complete DESIGO RXC system is commissioned.

#### Notes

- The LON bus plug (terminals 23 and 24) can be removed and reconnected at any time, even while the controller is in operation. Only the original bus plug may be used.
- Overloading outputs Y1 ... Y4 may cause the thermal fuse to trip and disable the controller. After solving the problem, briefly disconnect and reconnect the power supply. The controller will resume normal operation after a delay of approximately 10 minutes.



#### Note!

- Outputs Y1 ... Y4 are not protected against accidental connection to AC 24 V. This can damage the triacs.
- For accurate measurement of the air volume, make sure that the tubes are connected correctly.

## Technical data

Power supply	Operating voltage	SELV / PELV AC 24 V $\pm$ 20 %
	Rated voltage	AC 24 V
	Frequency	50/60 Hz
	Power consumption	
	Without field devices	6 VA
With field devices	Max. 33 VA	
Inputs	Internal fuse	Thermal, automatic reset
	Supply cable protection (external fuse)	$\leq$ 10 A
	Signal inputs for volt-free contacts	
	Quantity	2 (D1, D2)
	Contact voltage	DC 33 V
	Contact current	DC 8 mA
	Contact transfer resistance	Max. 100 $\Omega$
	Contact insulation resistance	Min. 50 k $\Omega$
	Not suitable for pulse control	
	Measured value input for temp. measurement	
Quantity		
Suitable temperature sensors	1 (X1) <sup>1)</sup>	
Measuring range	LG-Ni 1000	
Sensor current	-40 ... 110 °C	
Resolution	2.5 mA	
Accuracy	$\leq$ 0.2 K	
1) X1 selected by option button in RXT10 tool	At 25 °C $\pm$ 0.2 K	
LG-Ni 1000 / 0 ...10 V		
Outputs	Triac outputs AC 24 V	
	Quantity	4 (Y1 ... Y4)
	Output voltage	AC 24 V on/off, PDM or 3-position (selected by switch)
	Output current	Max. 0.5 A
	Total nominal load (load on all outputs simultaneously)	Max. 24 VA
Flow sensor	Tube connections (nipple diameters)	$\varnothing$ 4.9 mm / $\varnothing$ 5.6 mm / $\varnothing$ 6.6 mm
	Measuring range	0...300 Pa
	Overload range	0...1400 Pa
	Volume measurement	
	Accuracy with dynamic calibration	CEN TC247 Accuracy class 2
	Accuracy with static calibration	CEN TC247 Accuracy class 1
	Air filter	Example: air filter ALG 3 ½ SPF Can be ordered from Schupp AG ( <a href="http://www.sf-filter.ch">www.sf-filter.ch</a> ), order number AL700/1.
Interfaces	Interface with room unit	
	Number of room units connectable	Max. 1
	Interface type	for room unit PPS2 for RXT10 LON
	PPS2 baud rate	4.8 kBit/s
	LON baud rate	78 kBit/s
	LON bus	
	Interface type	LON (LONMARK-compatible), electrically isolated
	Transceiver	FTT-10A
	Baud rate	78 Kbps
	Bus topology and bus termination	See Installation guide, CA110334



Cable connections	Plug-in terminal blocks	Rising cage terminals
	Solid conductors	1 x 0.2 ... 2.5mm <sup>2</sup> or 2 x 0.2 ... 1.0 mm <sup>2</sup>
	Stranded conductors without connector sleeves	1 x 0.2 ... 2.5mm <sup>2</sup> or 2 x 0.2 ... 1.5 mm <sup>2</sup>
	Stranded conductors with connector sleeves (DIN 46228/1)	1 x 0.25 ... 2.5mm <sup>2</sup> or 2 x 0.25 ... 1.0 mm <sup>2</sup>
	Max. tightening torque	0.6 Nm
	Single cable lengths	See Installation guide, CA110334
	Signal inputs D1, D2	Max. 100 m with diameters ≥ 0.6 mm
	Measured value input X1	Max. 100 m with diameters ≥ 0.6 mm
	Triac outputs AC 24 V, Y 1 ... Y4	Max. 100m where A ≥ 1.5 mm <sup>2</sup>
	Interface to room unit	Max. 115 m where A= 0.75 mm <sup>2</sup> (including tool connecting cable)
	Cable type	4-core, twisted pair, unscreened
	LON bus	See Installation guide, CA110334
	Cable type	See Installation guide, CA110334
	Tool connecting cable	Max. 3 m length
Housing protection standard	Protection standard to EN 60529	IP30 with terminal cover fitted and wall mounted without DIN rail All other mounting arrangements: IP20
Protection class	Insulation protection class	III
Ambient conditions	Operation	Class 3K5 to IEC 60,721-3-3
	Temperature	0 ... 50 °C
	Humidity	< 85 % rh
	Transport	Class 2K3 to IEC 60,721-3-2
	Temperature	- 25 ... 65 °C
	Humidity	< 95 % rh
Standards and directives	Automatic electronic controls for household and similar use	EN 60730-1
	Electromagnetic compatibility	
	Immunity (domestic)	EN 60730-1
	Emissions (domestic)	EN 60730-1
	<b>CE</b> compliance	
	Meets requirements of EMC directive	2004/108/EC
	<b>UL</b> compliance	UL916
<b>C</b> C-Tick conformity (EMC)	AS/NZS 61000-6-3	
Environmental compatibility	The product environmental declaration	ISO 14001 (Environment)
	CA2E3844 contains data on RoHS compliance, materials composition, packaging, environmental benefit, disposal	ISO 9001 (Quality) 2002/95/EC (RoHS)
Dimensions	See dimension diagrams	
	Width in DIN modular spacing units	8.5
Weight	Excluding packaging	0.28 kg

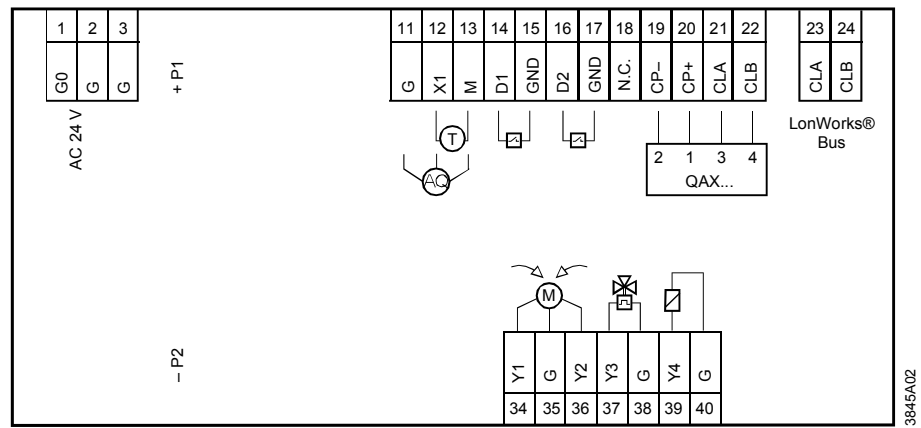

**Power supply**

- G0 1 Controller ground
- G 2 AC 24 V supply

**Analogue inputs and outputs**

- G 3 AC 24 V supply for sensor or actuator

**Measured value inputs for temperature or air quality sensors**

- G 11 AC 24 V supply for sensor
- B1 12 Measured value input for sensor (Ni1000 or DC 0 ... 10 V)
- M 13 Sensor ground

**Signal input for volt-free contacts**

- D1 14 Signal input
- GND 15 Signal input ground
- D2 16 Signal input
- GND** 17 Signal input ground
- N.C. 18 Not connected

**Room unit**

- CP- 19 PPS2 ground
- CP+ 20 PPS2 data
- CLA 21 Data A
- CLB 22 Data B

**LON bus (plug-in)**

- CLB 23 Data B
- CLA 24 Data A

**Triac outputs**

- Y1 34 AC 24 V, 0.5 A switching output
- G 35 AC 24 V actuator supply
- Y2 36 AC 24 V, 0.5 A switching output
- Y3 37 AC 24 V, 0.5 A switching output
- G 38 AC 24 V actuator supply
- Y4 39 AC 24 V, 0.5 A switching output
- G 40 AC 24 V actuator supply

**Air flow sensor**

- P1, P2 Air flow sensor connectors

**Tool socket**

Standard RJ45 tool socket for LON devices.

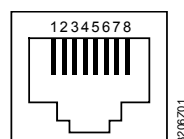

- 1 LON, Data A (CLA)
- 2 LON, Data B (CLB)
- 3 Not used
- 4 Not used
- 5 Not used
- 6 Not used
- 7 PPS2 (CP+)
- 8 PPS2 (CP-)

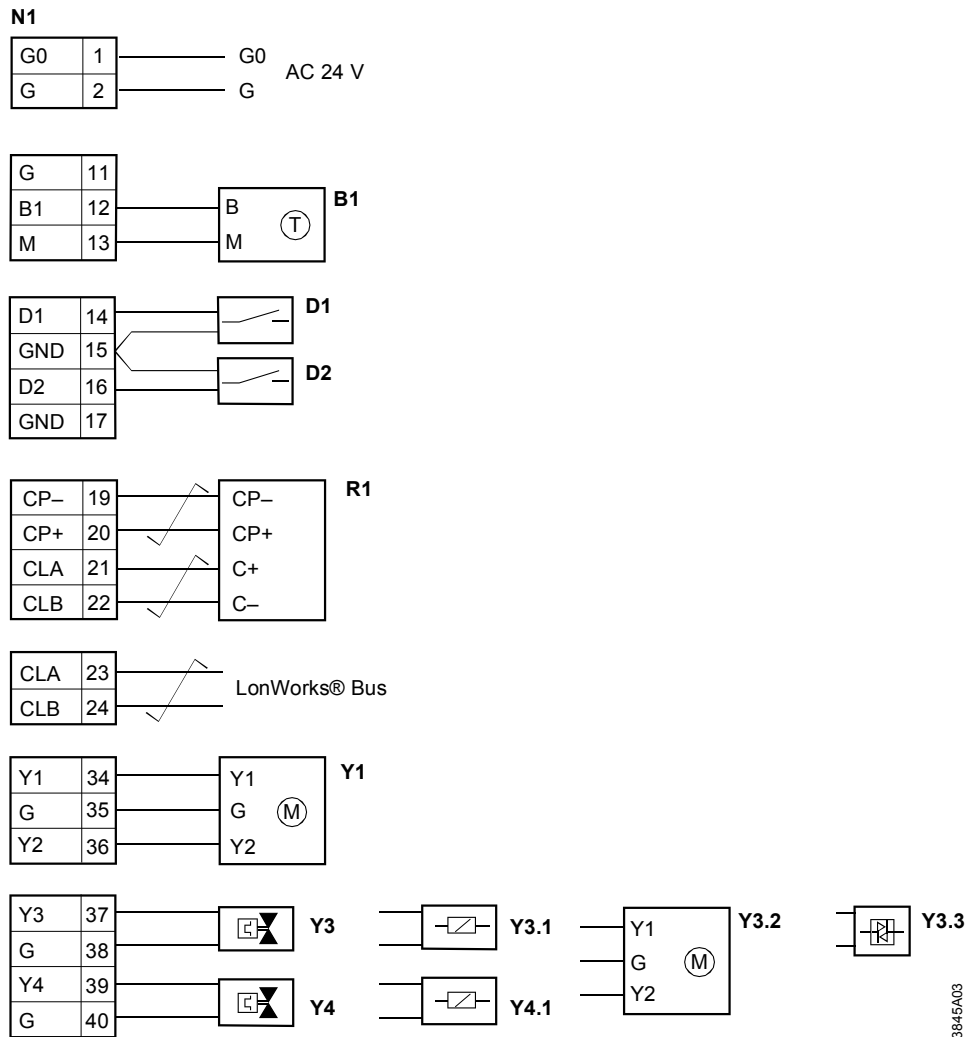

- N1 RXC32.1
- X1 Temperature sensor LG-Ni 1000
- D1, D2 Volt-free contacts (window switch, occupancy sensor, etc.)
- R1 QAX... room unit
- Y1, Y3.2 AC 24 V 3-position damper actuator types GDB13..., GLB13...
- Y3, Y4 AC 24 V thermic valve actuators
- Y3.1, Y4.1 AC 24 V contactors for electric heating coil
- Y3.3 Solide state relays AC24V

- Notes
- Do not exceed the maximum simultaneous load on outputs Y1 ... Y4 (see "Engineering")!
  - A power amplifier may be used to connect additional valve actuators to Y3 and Y4 (see DESIGO RXC installation guide, CA110334).
  - For information on actuators compatible with the RXC32.1 controller, refer to the relevant application descriptions (see DESIGO RXC applications library, CA2A3810)
  - The voltage for devices with an AC 24 V supply (G) can be derived either from the controller or from an external source (see the DESIGO RXC installation guide CA110334).
- If the connected devices receive their supply from the controller the power consumption of these devices must be taken into account when sizing the transformer.

3845AC3

**Parallel connection of several thermic actuators**

Up to 2 thermic actuators can be connected directly to the room controller. In the case of more than 2 actuators a power amplifier is required.

The same principle applies to output Y3.

Note that the simultaneous load on outputs Y3 and Y4 must not exceed 9.5 VA.

Power consumption at input X1 of the UA1T: 0.5 VA.



**Note!**

Mixed operation: **Connecting thermic actuators to the controller as well as to the power amplifier is NOT allowed.**

Differing voltage of the power supply of the controller and the supply of the power amplifier may cause big differences in the position of the valves.

Connection to controller

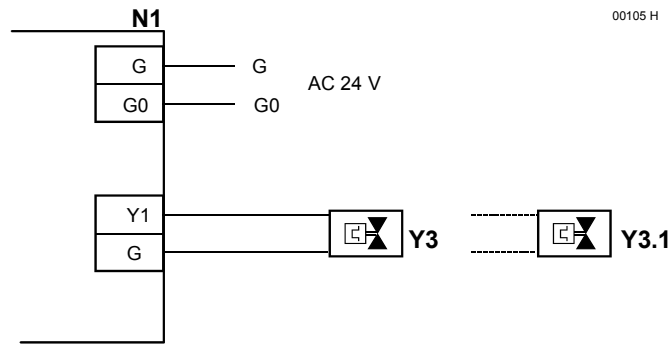

00105 H

Connection to power amplifier

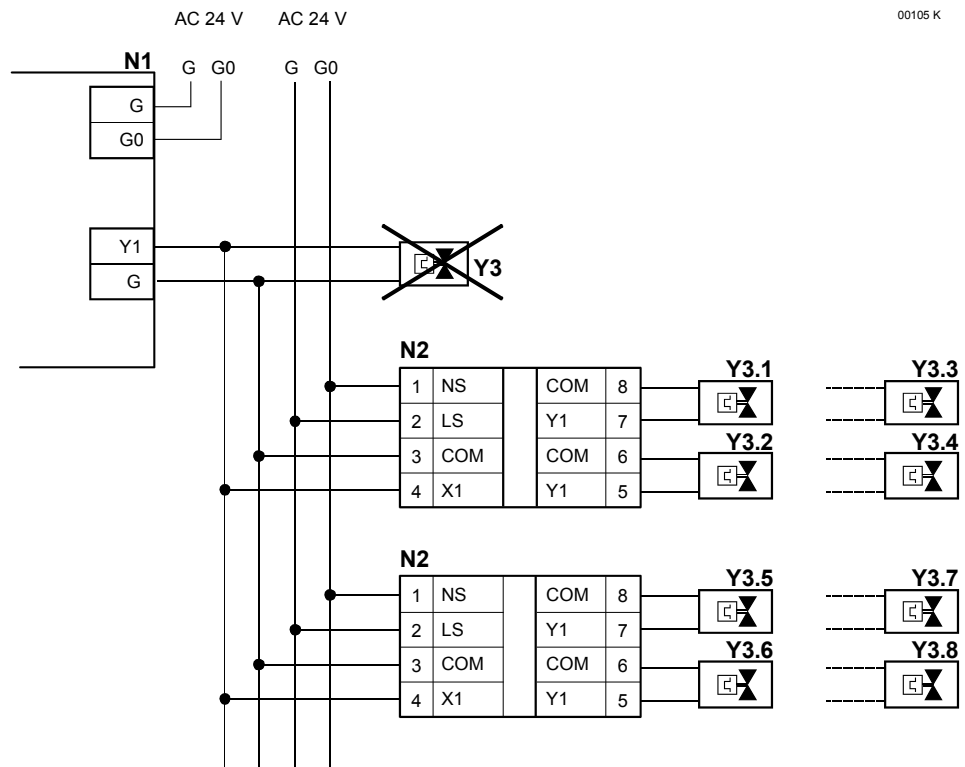

00105 K

- N1 RXC32.1
- N2 UA1T (see data sheet CA2N3591)
- Y3 AC 24 V thermic valve actuator
- Y3.x AC 24 V thermic valve actuator (max. 2 STA72E / STP72E actuators per Y1 output on the UA1T)

**Notes**

- The UA1T requires an AC 24 V supply voltage
- The UA1T is *not* suitable for the connection of 3-position actuators.

## Dimensions

All dimensions in mm

### Without terminal covers

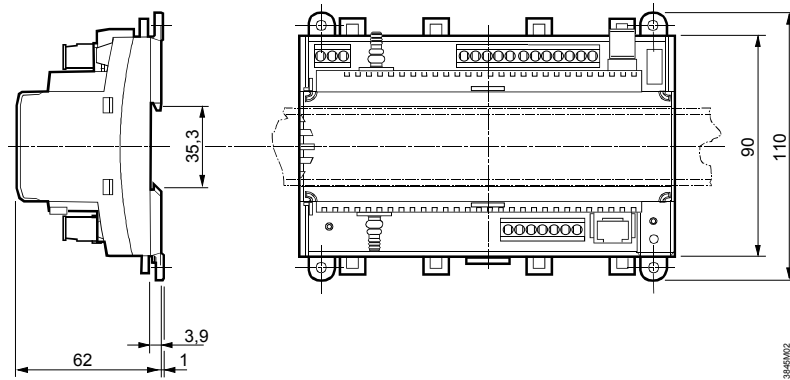

### With terminal covers

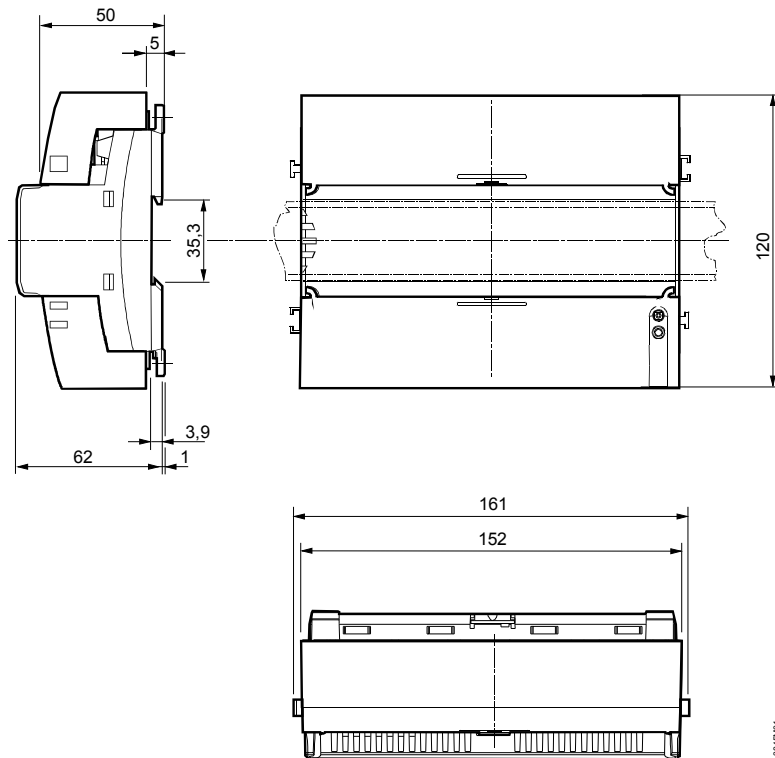

### Drilling diagram

